

NUCRAFT

Approach Installation Instructions

ID:

Before Beginning Installation

- Read through the entire instruction thoroughly
- A minimum of 2 persons is required for this assembly
- These instructions reflect typical assemblies. They may not match your specific configuration.

Required Tools

- #3 Phillips Head Bit or Driver
- 5/16 Allen Wrench
- Provided Hardware
- Included Hardware:
 - HW8017 Bolts



- HW0573 Screws



Step 1: Leg to Base

- Remove base from packaging and stand on square plates.
- Remove bolts (12) and washers (12) that are used to fasten legs.
- Remove legs from packaging and align holes on center of legs to holes in base.
 - NOTE: The glides must be facing towards the inside of the base after assembly.
- Fasten legs by replacing the bolts and washers.

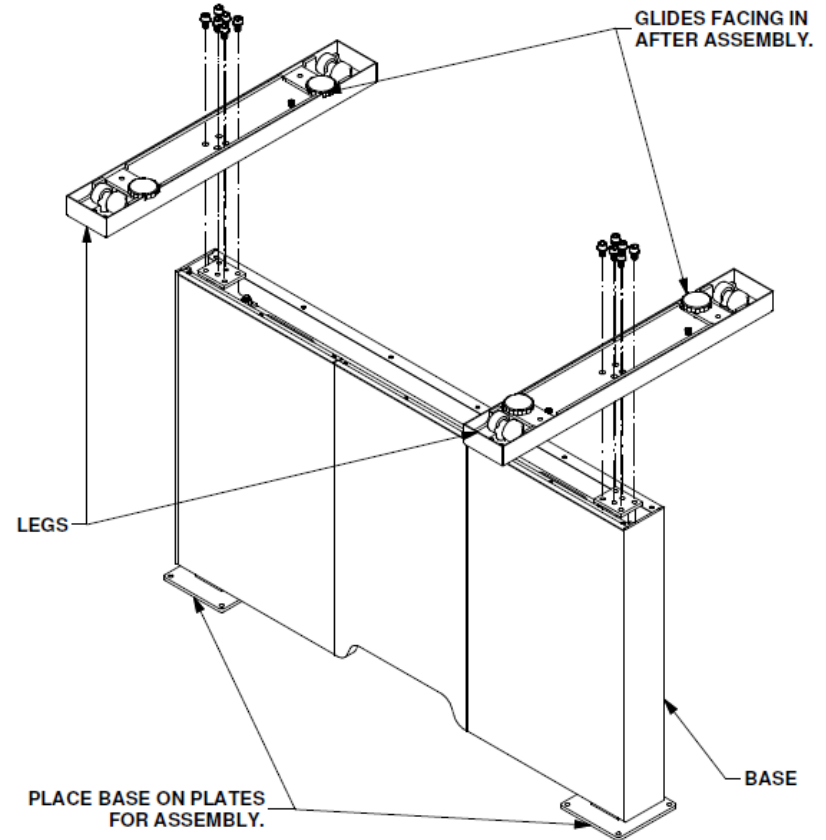

Step 2: Flip Base

Flip base to correct orientation before adding top.

NOTE: LEG SHROUDS ARE NOT WEIGHT BEARING

- Flipping base to the front can cause damage to the legs.
- Instead flip table to the side with caution to avoid any damage.

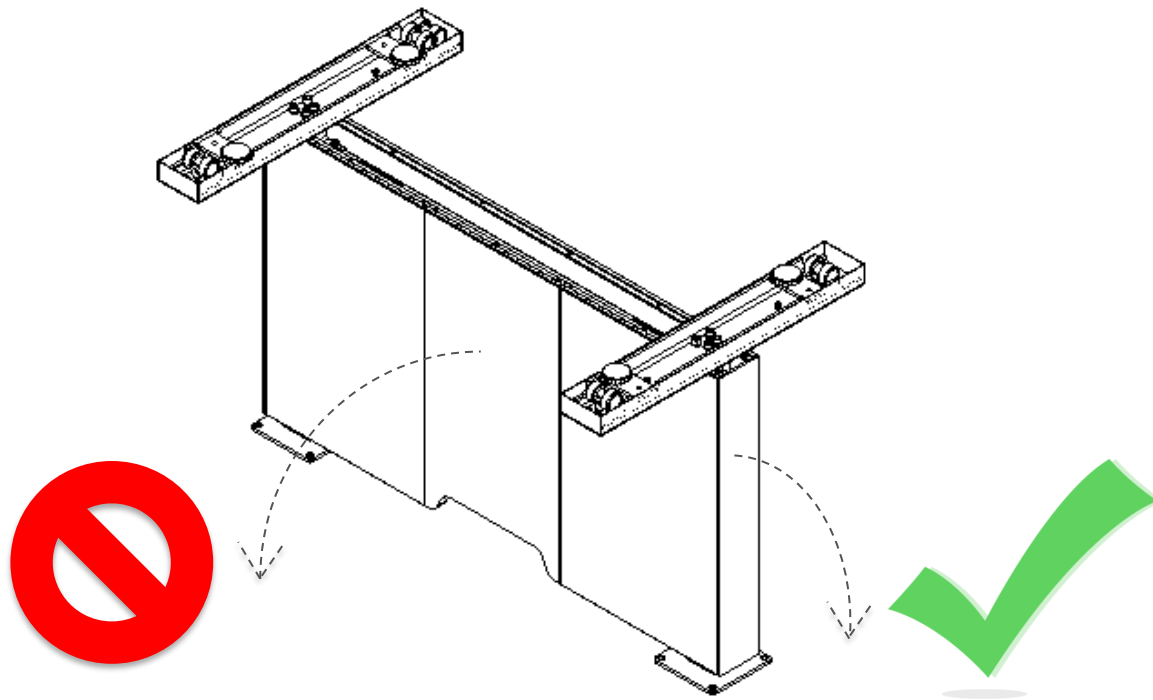

Step 3: Base to Top

- Place top onto base by placing the square plates into tilt mechanism.
- NOTE: When base is assembled to top, the orientation of the door needs to face the tilt activation lever.
- Fasten four screws at both tilt mechanism connection points, totaling eight screws to attach the base to the top.

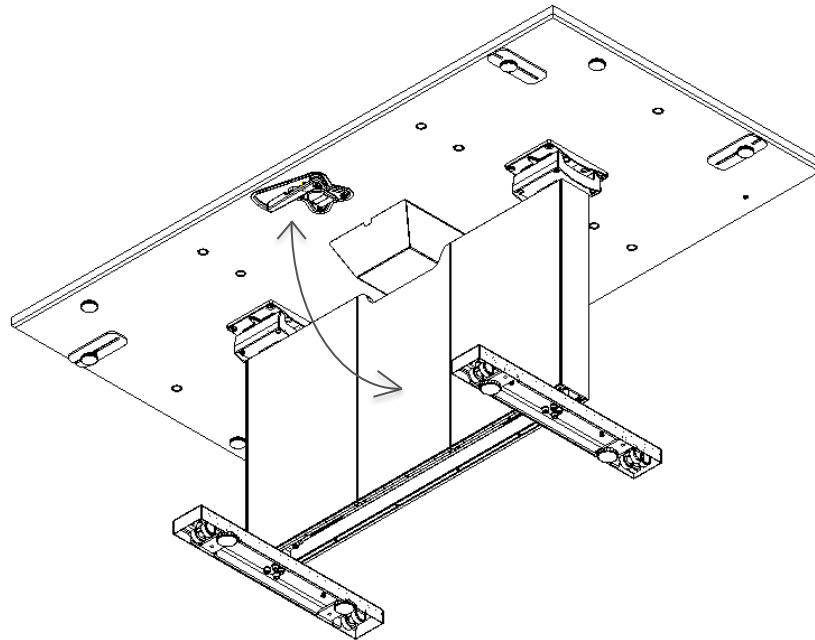

Step 4: Leveling

- To level the table, adjust the glides on the underside of the foot.
- NOTE: The intent is to keep the tables level while also allowing the caster to engage with the floor.

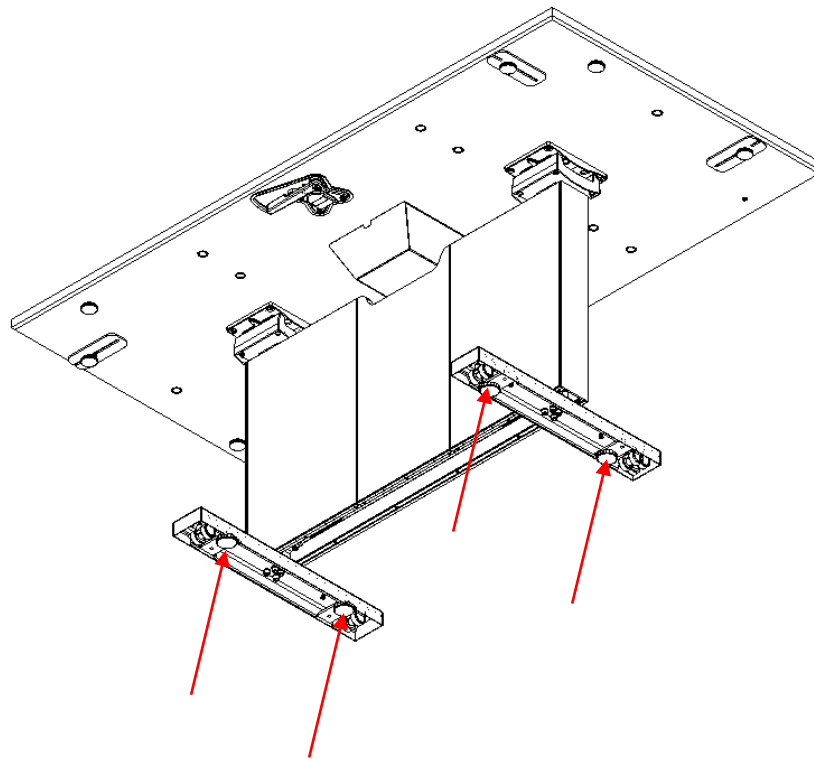

Typical Table Labeling

See examples on the next page of typical labeling for a grain matched set. Each top will have two letters that are used to match the correct sides to their corresponding partners.

“A” will match to the corresponding “A”, “B” will match the corresponding “B”, and so on..

APPROACH GRAIN MATCHED TOPS



5 TOP

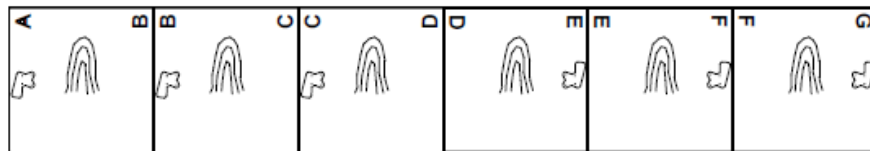

6 TOP

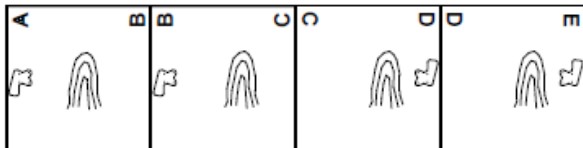

4 TOP

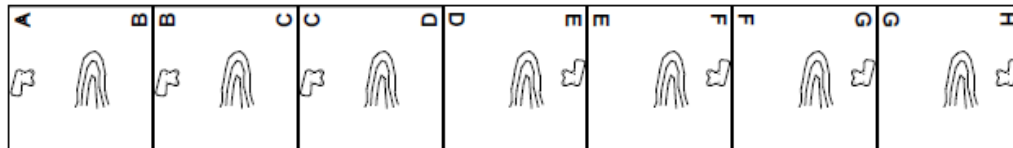

7 TOP



3 TOP

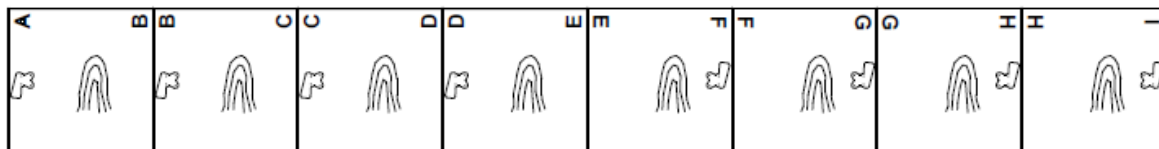

8 TOP

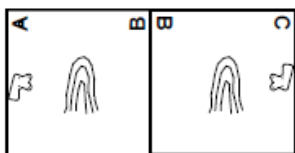

2 TOP

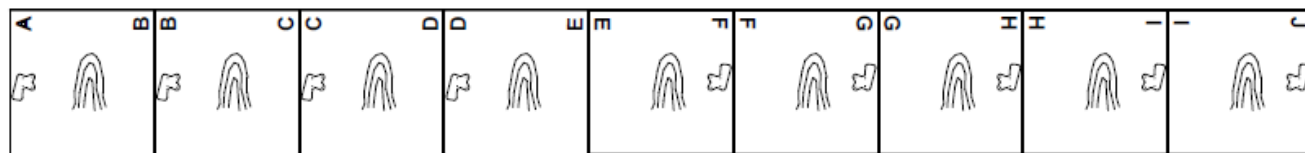

9 TOP

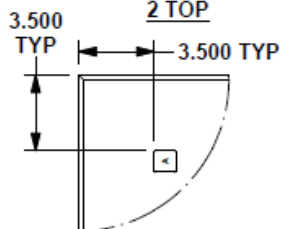

DETAIL A

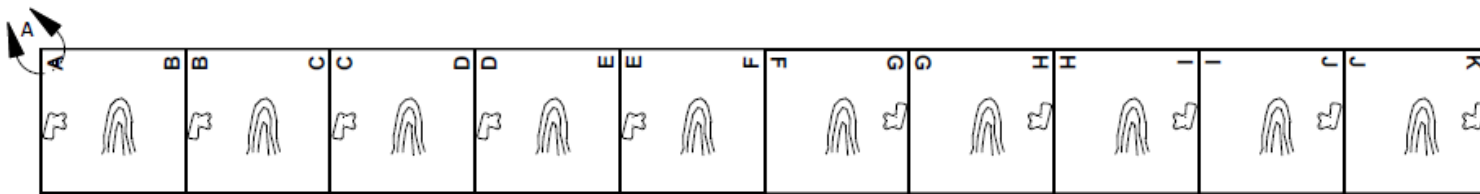

10 TOP