

NUCRAFT

Approach Installation Instructions

Before Beginning Installation

- Read through the entire instruction thoroughly
- A minimum of 2 persons is required for this assembly
- These instructions reflect typical assemblies. They may not match your specific configuration.

Required Tools

- #3 Phillips Head Bit or Driver
- 5/16 Allen Wrench
- Provided Hardware:

HW8017 Bolts



HW0543 Screws



Step 1: Leg to Base

- Remove base from packaging and stand on square plates
- Remove bolts (12) and washers (12) that are used to fasten legs.
- Remove legs from packaging and align holes on center of legs to holes in base.
Note: The glides must be facing towards the inside of the base after assembly.
- Fasten legs by replacing the bolts and washers.

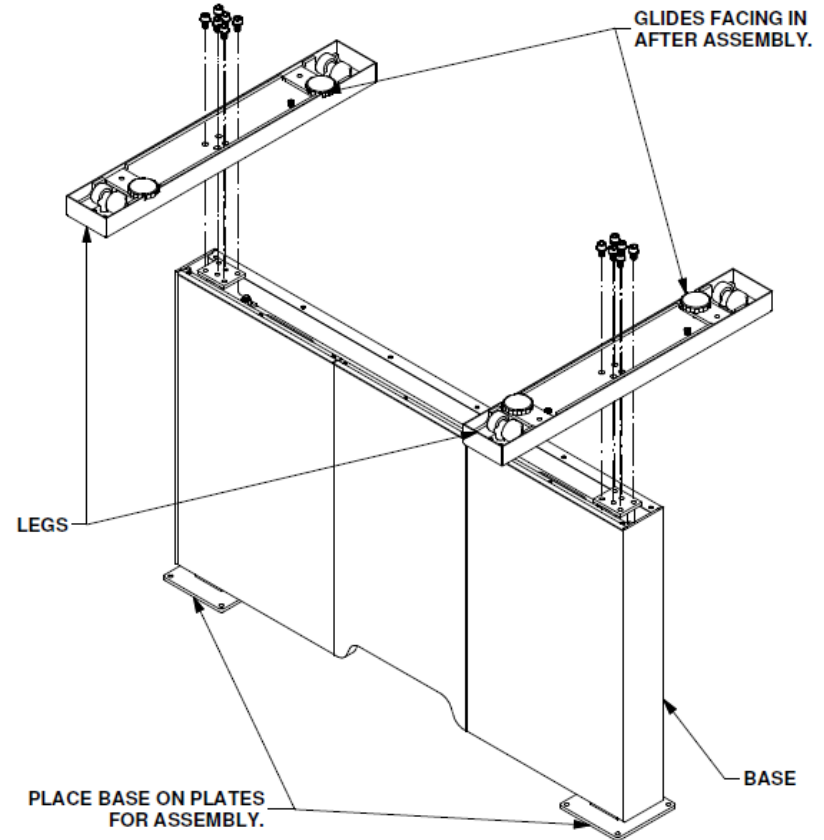

Step 2: Base to Top

- Remove top from packaging, and place onto a shipping blanket to ensure no damage to top.

Note: When base is assembled to top, the orientation of the door needs to face the tilt activation lever.

- Place square plates into tilt mechanism. Take care to NOT damage the underside of table.
- Fasten screws (4) at both tilt mechanism connection points, totaling 8 screws, to attach the base to the top.

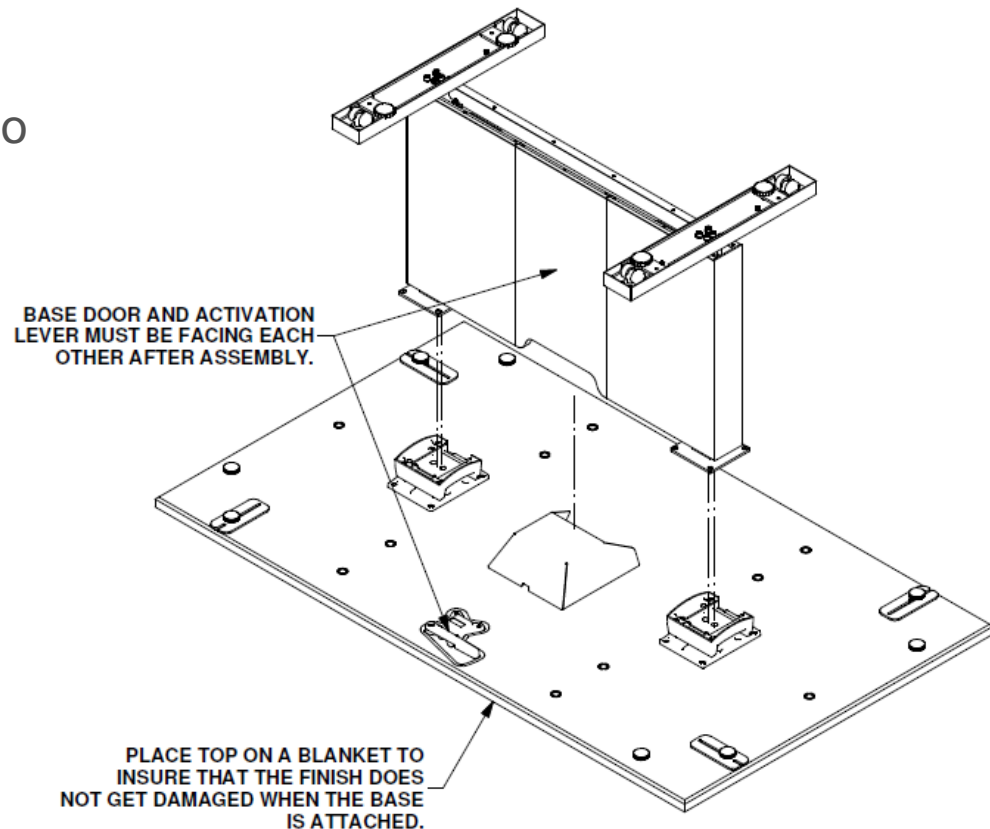

Typical Table Labeling

See example on the next page of typical labeling for a grain matched set. Each top will have 2 letters that are used to match the correct sides to their corresponding partners.

- “A” will match to the corresponding “A”, “B” will match to the corresponding “B”, and so on..

APPROACH GRAIN MATCHED TOPS



5 TOP

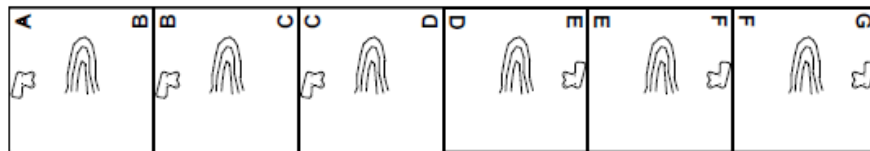

6 TOP

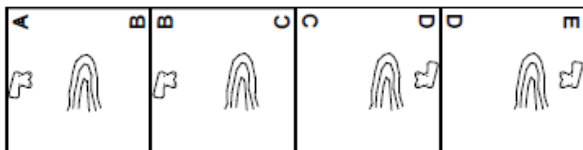

4 TOP

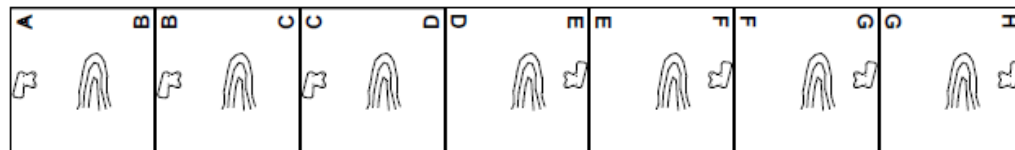

7 TOP



3 TOP

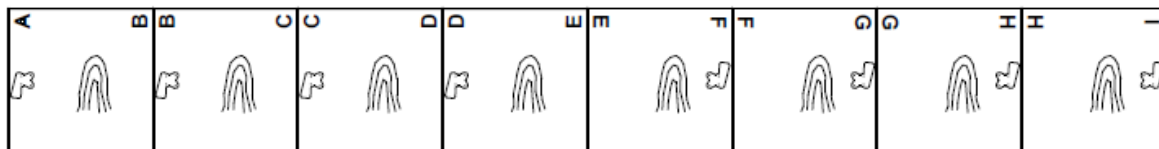

8 TOP

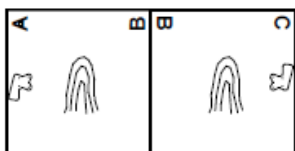

2 TOP

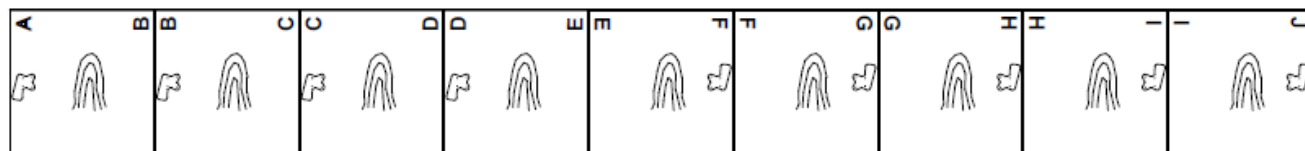

9 TOP

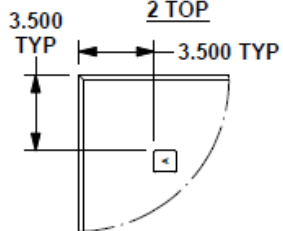

DETAIL A

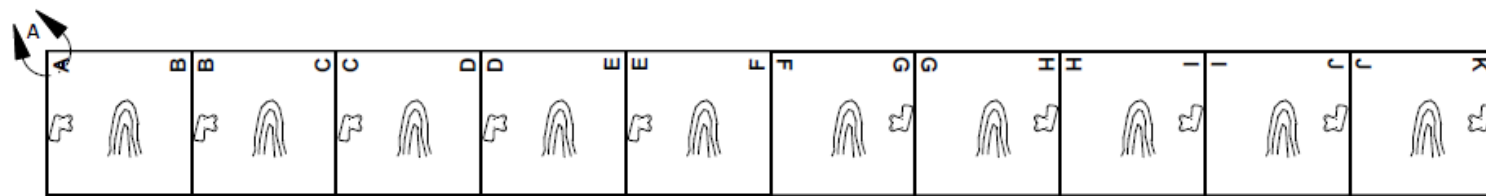

10 TOP