

NUCRAFT

Ativa Conference  
Installation Instructions  
ID:

# Before Beginning Installation

- Read through the entire instruction thoroughly
- A minimum of 2 persons is required for this assembly
- These instructions reflect typical assemblies. They may not match your specific configuration.

# Required Tools

- Drill Driver
- #2-#3 Phillips Bit
- ½" Nut Driver
- Laser Level
- Provided: Draw-Tight Fastener Tool

- Provided Hardware:
  - Doubled Ended Pin HW0459
  - Single Ended Pin HW0456
  - HW0613
  - HW4640
  - HW0664

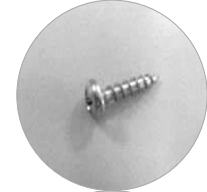

# Ativa with Door Access

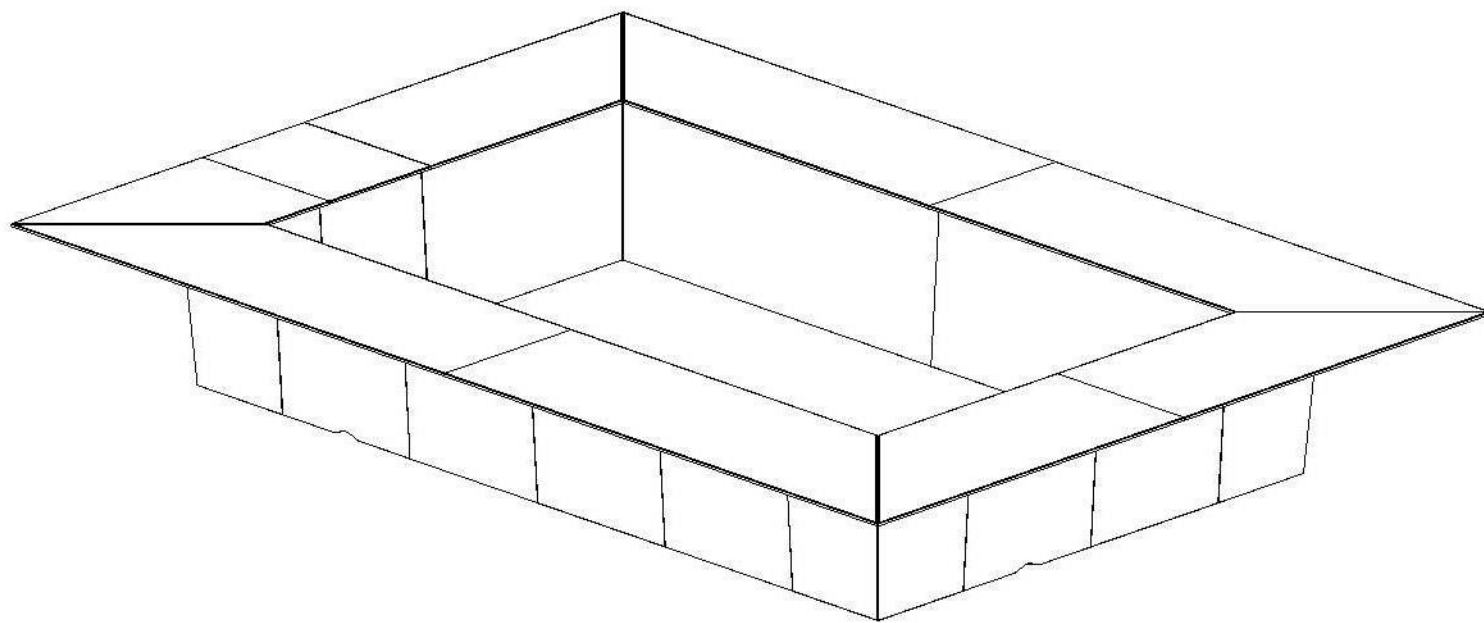

# Ativa U-Shape Exploded

1. Top
2. Shroud
3. Modesty Panel
4. End Panel
5. Support Frame
6. Access Panel

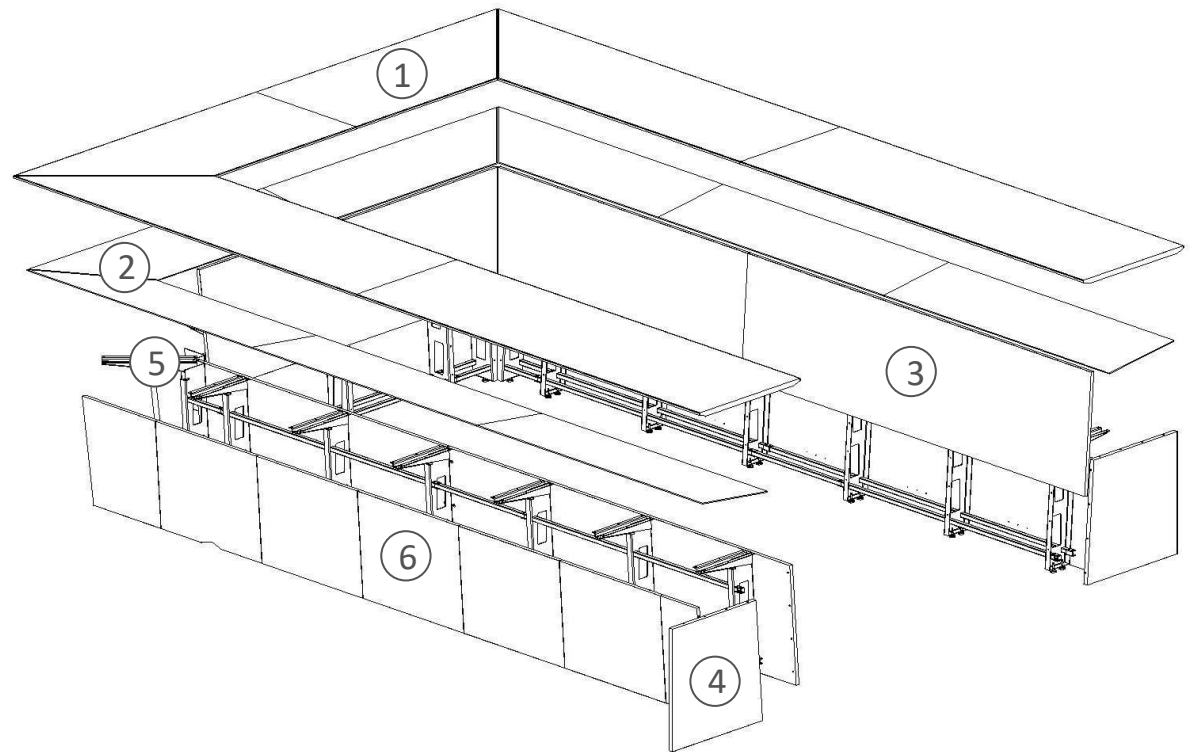

# Step 1: Layout and Support Frame Installation

- Remove parts from packaging, using care to avoid any damage.
- Arrange support frame on a clear, stable surface.
  - Panels are labeled for proper alignment.
- NOTE: This is when the table should be placed in desired location and the frame leveled.
  - It is difficult to build table and then move to desired location; damaged will occur.

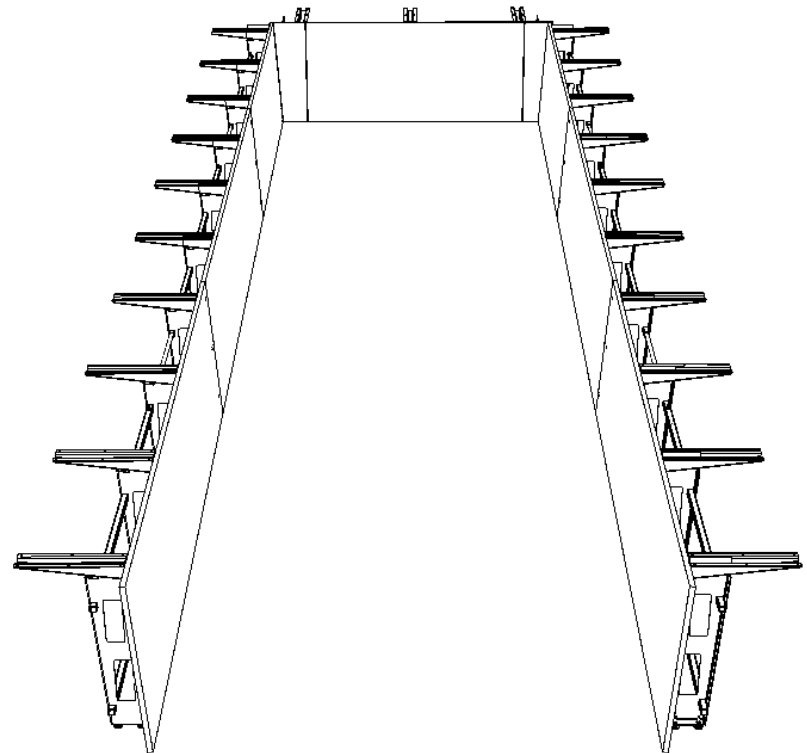

## Step 2: Connecting Support Frame Panels

- Connect modesty panels together with cams using the double ended pins (HW0459).
- Align corners to trim piece and fasten with HW4640.
- Tighten bolts on the frame once all panels are connected.

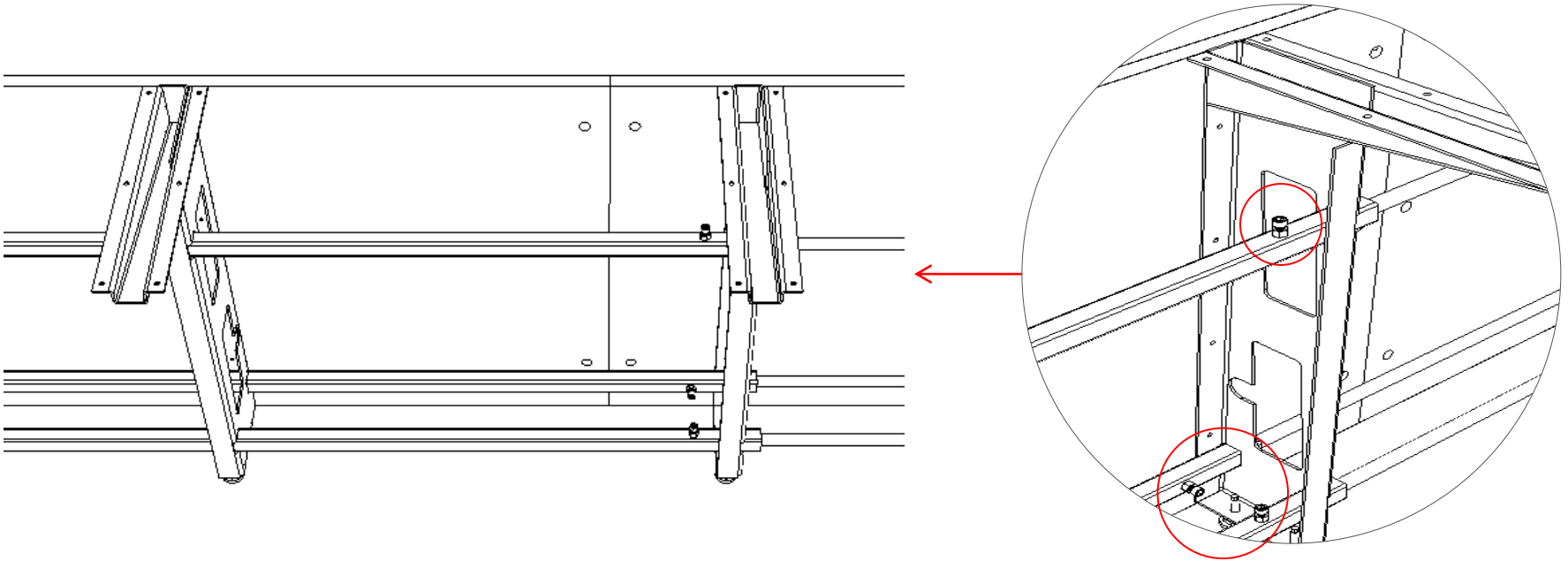

## Step 3: Installing Tops

DO NOT install corner frames until top has been installed and tight jointed together.

- Place tops over the base frames.
  - Reference the trace marks on the underside of the tops to align with frame gussets.
- Place draw-tight fastener's in the grooves at each seam. Tighten with the provided draw-tight fastener tool.
- Fasten all tops to base frame with HW0664.

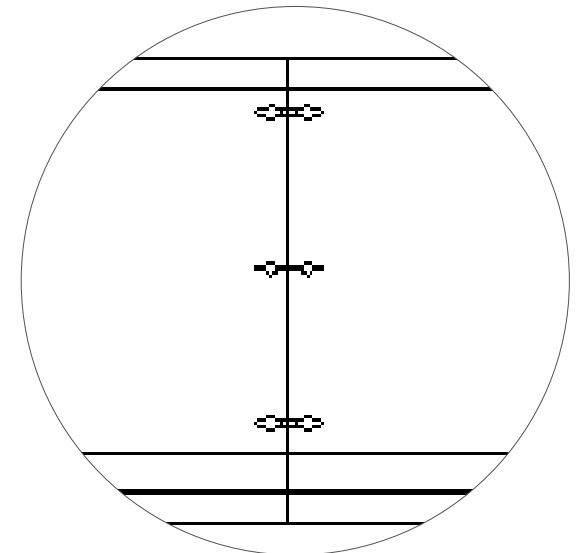
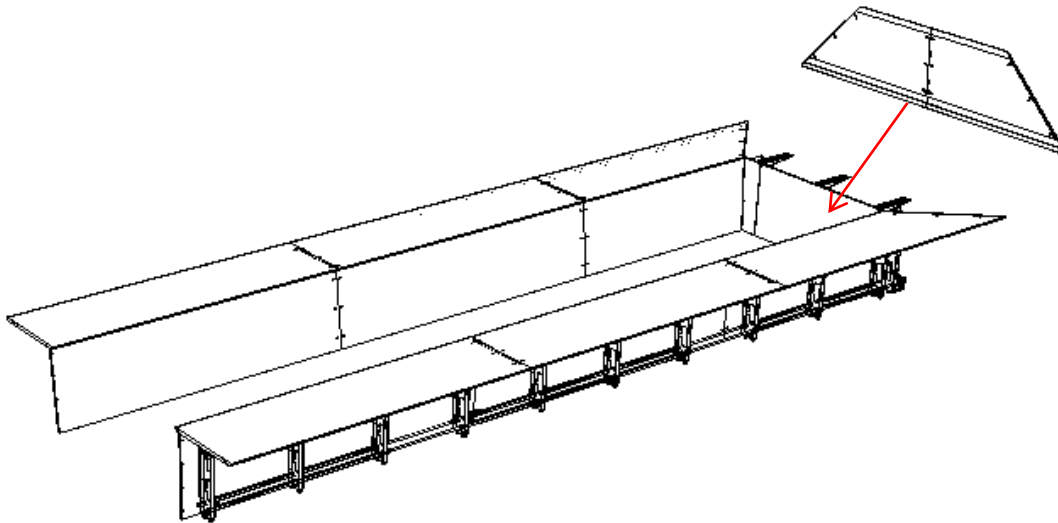



## Step 4: Installing Corner Supports

Attach the corner supports to the base:

- Align the corner and fasten to modesty panels using HW0613.
- Attach connecting rods and tighten the ½" bolts once in place.

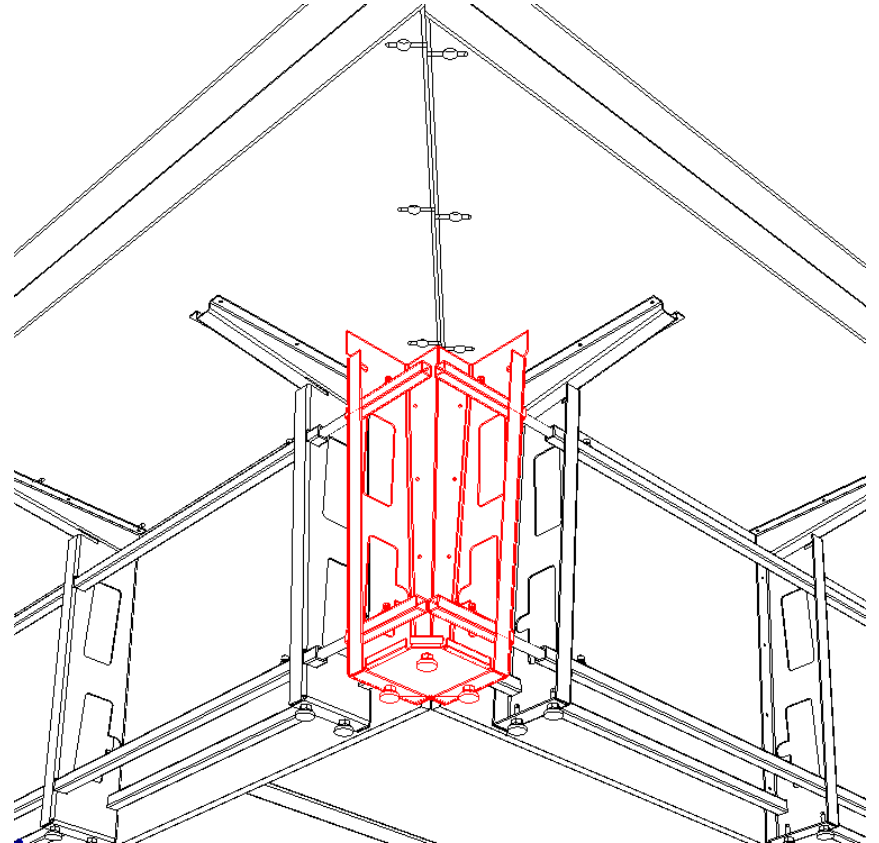

## Step 5: Installing Wiring

Once all tops and base frames are set, feed electrical through the base frames.

NOTE: This can be done at a later time with additional wiring.



## Step 6: Installing Access Doors

Four Sided tables only:

- Install access door once tops are in place.
  - NOTE: Tops may need minor adjustments for door to fit properly.
- Top door is fastened with the provided piston hinges.
  - Attach the hinge to the top door using HW0613.
- Bottom doors snap onto the hinge plates.



## Step 7: Installing Shrouds

- Install shrouds onto underside of table.
  - Shrouds are labeled in a numerical order.
- Shrouds ride in the channel on the underside of the top, and base frame assembly.
- Where two shrouds meet, use clear trim piece to join together.
- Use provided fasteners for added stability. Fastener goes in the frame leg groove. Sits up to the shroud, but does not drill through shroud.

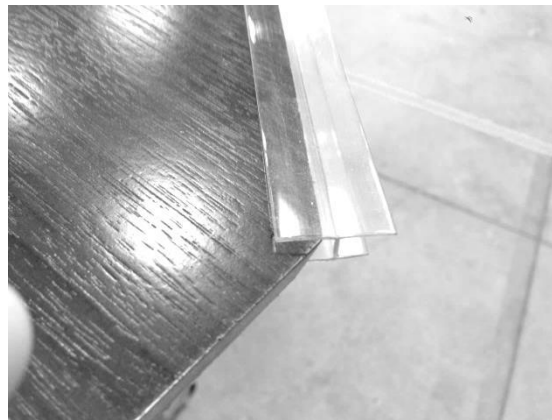
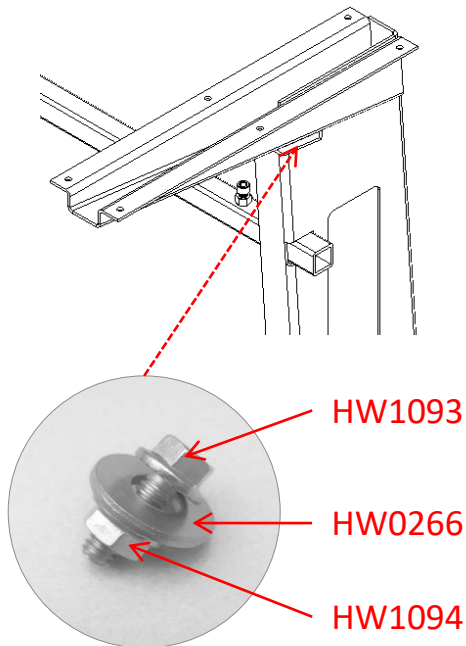

## Step 8: Installing Access Panels

Attach access panels to the frame:

- Panels are labeled on the back side in numerical order.
- Panels attach with pre installed z-hooks that hang on the frame.
- Attach access panel shim to the z-hook. Peel the backer off the double sided tape and press into the z-hook. Be sure the shim is pressed all the way to the front of the z-hook, and not towards the back by the panel.
- Hang panel by the z-hook.

