

BAJA™

GSA Planning Guide + Price List

QUICK LINKS

[PLANNING GUIDE](#)

[BAJA PRICING](#)

[POWER AND DATA OPTIONS](#)

[GENERAL INFORMATION](#)

[FINISH INFORMATION](#)

[SURFACE MATERIALS](#)



TABLE OF CONTENTS

Click the shortcuts below to jump to each section.

General Information	ii-iii
Finish Information	iv-v
Surface Materials	vi-vii
Statement of Line	3
Specification Overview	4
Baja Tops and Bases	27-51
Power and Data Options	52-61

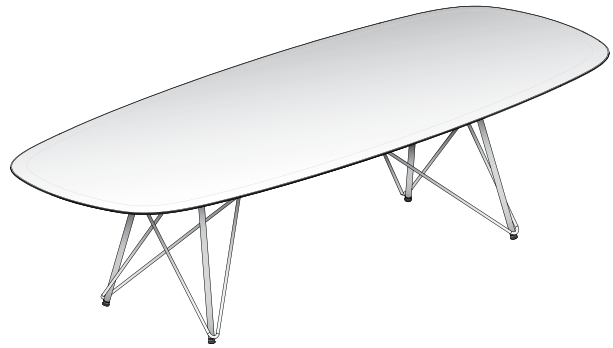



STATEMENT OF LINE

CONFERENCE TABLES

Pages 27-51



Round



Square



Soft Square



Rectangle

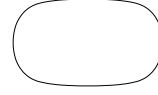

Soft Rectangle

BASES

Pages 27-51

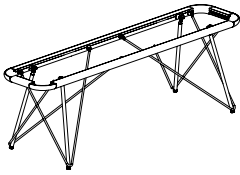

Wire Frame

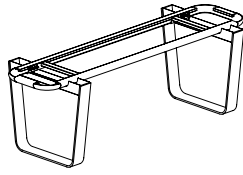

Hoop Base



SPECIFICATION OVERVIEW

1. Select the Top Shape

Options include Round, Square, Soft Square, Rectangle and Soft Rectangle.

2. Select the Top Surface Material

Choose between standard veneer with hardwood edge, laminate with either square edge or hardwood edge, and back-painted glass.

3. Select the Top Size

Sizes range from 42" to 60" wide and from 72" to 240" long.

4. Select the Top Edge Profile

Baja tables are offered with two edge profile options on non-glass tops.

- Surf Edge Profile: This edge profile is characterized by a gentle radius along the entire perimeter of the table top. This edge profile is offered in veneer with hardwood edge only. The bottom of these table tops features a black polymer resin and the same radius along the perimeter of the table, creating a unique edge profile that gives it both a thick and thin aesthetic.

- Crest Edge Profile: This edge profile features a flat top with an undercut edge. It is available on veneer and laminate tops.

5. Select the Base Style and Finish

Baja tables are available with two base options:

- Wire Frame: This base style features four steel posts and a steel "wire" design. All surfaces are available in powder coat with options for polished chrome or blackened nickel plating.

- Hoop Base: This base style features an open steel hoop design and is available in powder coat as well as options for polished chrome or blackened nickel plating.

6. Select the Power/AV Option (if desired)

Options for power and AV connectivity include:

- Table Top: Tech Node or Power Matrix (Small or Medium versions)

- Sub-Top: Power Rail

TABLE TOP EDGE PROFILE STYLES

Baja tables are available with three top styles and edge profile combinations; Surf, Crest and Glass.

SURF TOP

These table tops are characterized by a gentle radius along the entire perimeter of the table top. They are offered in veneer with hardwood edge only. The bottom of these table tops features a black polymer resin and the same radius along the perimeter of the table, creating a unique edge profile that gives it a thick aesthetic that transitions down to a thin profile. Available in Round and Soft Square shapes (42" and 48") as well as a Soft Rectangle shape (from 72" to 120" in length, and 42" and 48" in width).

Surf Top

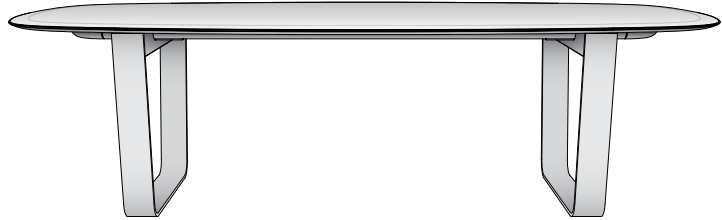

Surf Edge Profile

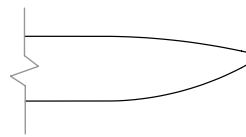

CREST TOP

These table tops feature a flat top with an undercut edge. They are offered in veneer with hardwood edge, inset laminate with hardwood edge and laminate with square edge. Available in Round, Soft Square and Square shapes (42" to 60") as well as a Soft Rectangle and Rectangle shape (from 72" to 240" in length and 42" to 60" in width).

Crest Top

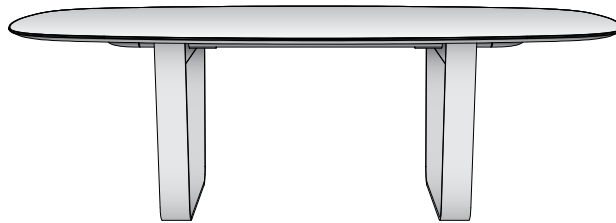

Crest Edge Profile

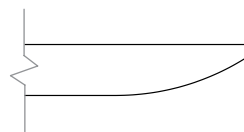

GLASS TOP

These tops feature a ¼"-thick back-painted glass top with pencil edge. The rests on a painted sub-top. Available in Round, Soft Square and Square shapes (42" to 60") as well as a Soft Rectangle and Rectangle shape (from 72" to 240" in length and 42" to 60" in width).

Glass Top

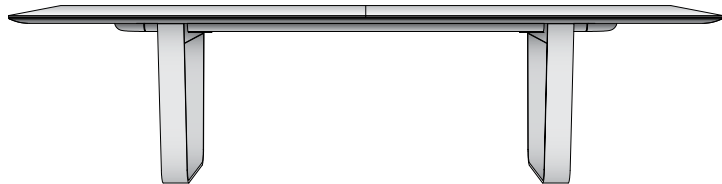

Glass Edge Profile

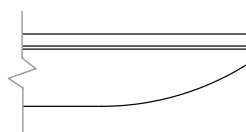



BASE OPTIONS

Baja tables are available with two base styles:

HOOP BASE

This base style features an open steel hoop design and is available in powder coat as well as options for polished chrome or blackened nickel plating. On tables longer than 144", a center Hoop base is included. An optional Center Column Base can be specified for additional cable storage and routing.

Hoop Base

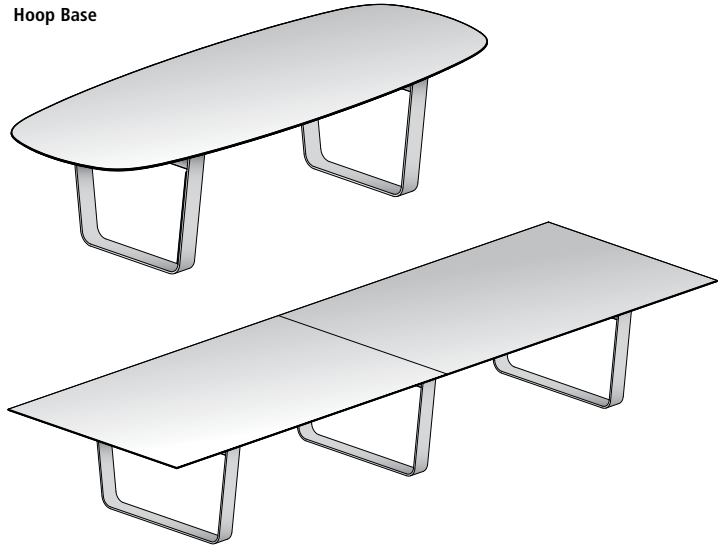

Hoop Base with Optional Center Column Base

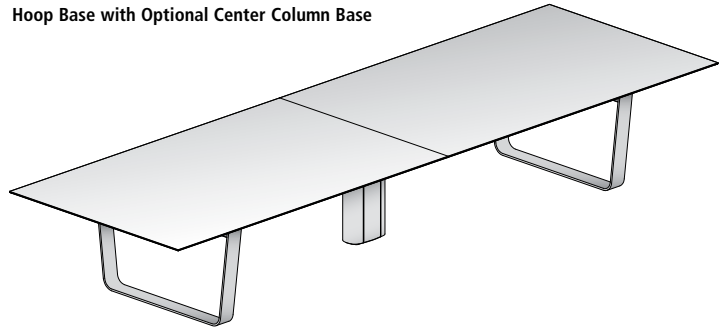

WIRE FRAME

This base style features four steel posts and a steel "wire" design. All surfaces are available in powder coat with options for polished chrome or blackened nickel plating. On tables longer than 144", a center base is included. The Center Column Base includes a hinged door for access to the inside of the base for cable storage and routing.

Wire Frame

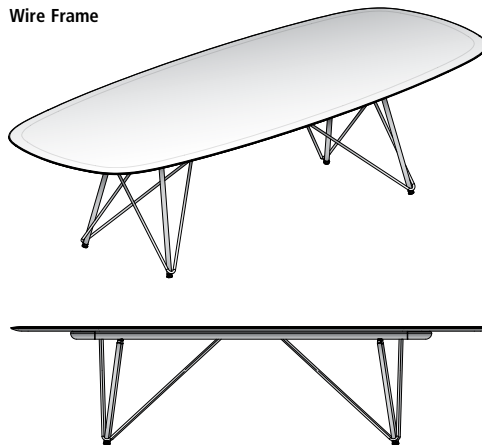

Wire Frame with Optional Center Column Base

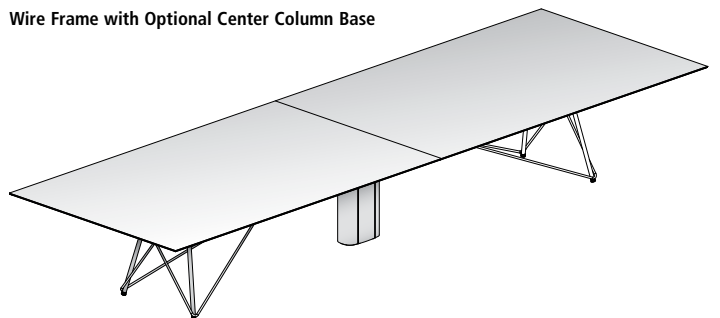

WIRE MANAGEMENT

For tables specified with power options, there are multiple choices relative to managing cables from the floor to the table top.

HOOP BASE

When the Hoop base is specified, a wire channel can be adhered to one of the vertical elements of the base. This channel includes a hinged door and is capable of storing an electrical infeed and several data cables. Each table includes one wire manager.

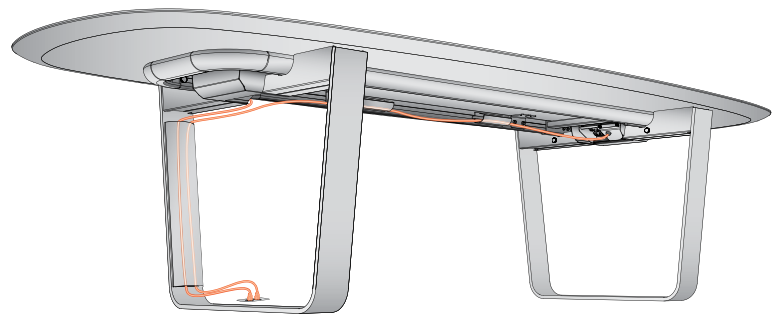

WIRE FRAME

When the wire frame base is specified, a wire channel can be attached to one of the four posts at the corners of the table. This channel is capable of storing an electrical infeed and several data cables. Each table includes one wire manager.



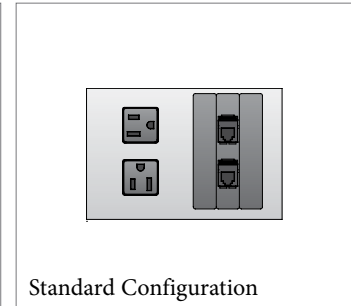
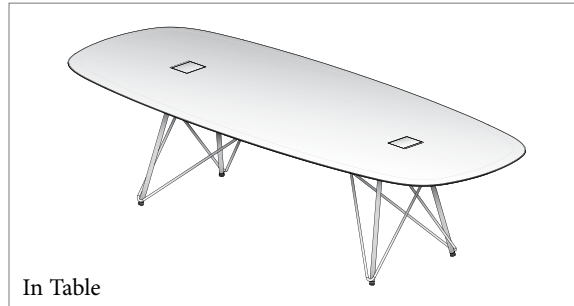

TABLE TOP POWER OPTION: POWER MATRIX

Available in a variety of sizes, styles and connectivity options, Power Matrix is Nucraft's most versatile power option. Power Matrix incorporates a broad array of scalable features and is available across multiple product lines, making it the "go to" solution for power and AV-connectivity needs.

Offered in a Small and Medium size on Baja tables, Power Matrix can handle any power and AV-connectivity need, from the simplest to the most demanding.

Small



Medium

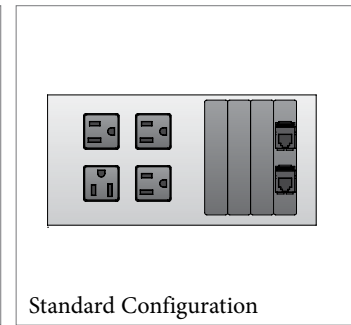
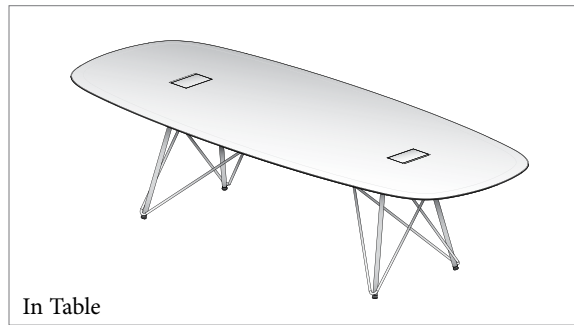
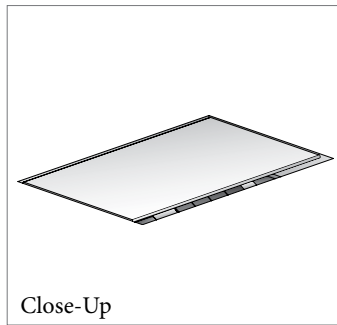

TABLE TOP POWER OPTION: POWER MATRIX

Power Matrix is filled with a broad array of high performance features and refined aesthetic elements.

POWER

Power Matrix features simplex receptacles for power connectivity, the quantity of which is pre-determined based on the size of the unit. An optional USB-A+C charger can also be specified in place of one of the simplex receptacles when desired. Corded or hardwired in-feed options add flexibility.

DATA/AV FACEPLATES

Power Matrix accommodates Modular AV Inserts/Plates for unparalleled flexibility in data and AV connectivity.

DESIGN

Power Matrix units feature a clear anodized aluminum body and a bezel-free flush mount design on wood tables for an elegant appearance. Laminate and glass table tops include a bezel, available in powder coat, polished chrome, blackened nickel plating, or clear anodized finish options.

PERFORMANCE

Friction hinges ensure smooth travel through the door's range of motion and can hold the door in any position. Hidden door stops maintain the minimalist aesthetic. Cable storage is both concealed and ample.

DOORS

Power Matrix is offered in multiple door material options, including metal, glass and grain-matched wood cut from the same table top.

(Medium size shown)

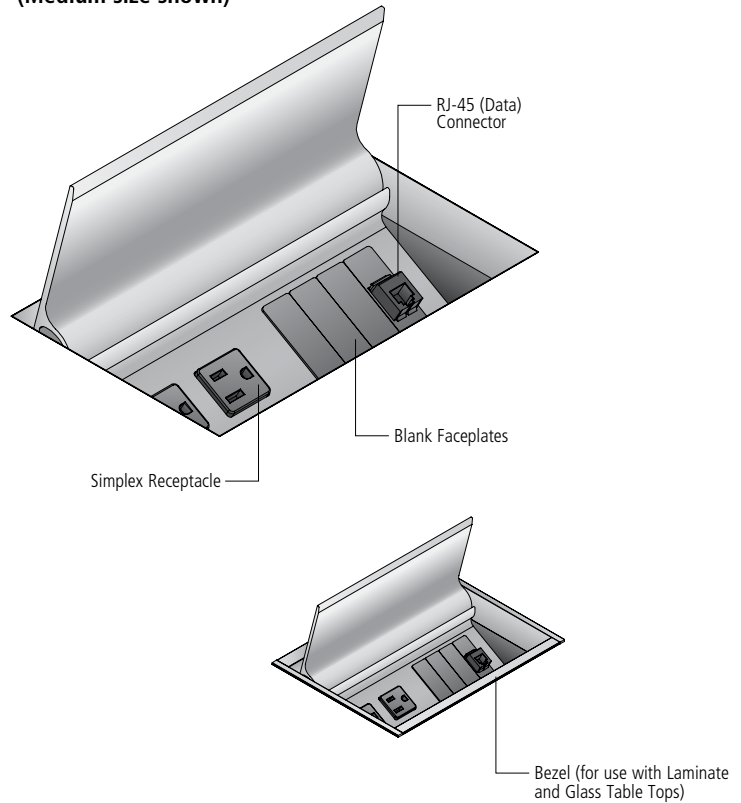



TABLE TOP POWER OPTION: POWER MATRIX

STANDARD CONFIGURATIONS

Power Matrix is available in two sizes for Baja, each with a pre-determined quantity of simplex outlets and AV faceplates. With each size, an optional 2 amp USB-A+C charger (1 amp per port) replaces one of the simplex outlets.

Small

- Single door design
- 5.375" x 6" cutout
- Two simplex outlets
- Three AV faceplates. Standard configuration includes two blank faceplates and one faceplate with two RJ-45 (CAT6) connectors.

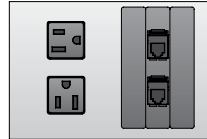

Medium

- Single door design
- 5.375" x 8.25" cutout
- Four simplex outlets
- Four AV faceplates. Standard configuration includes three blank faceplates & one faceplate with two RJ-45 (CAT6) connectors.

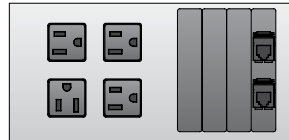

DIMENSIONS

Each Power Matrix unit includes a low-profile pan beneath the work surface to conceal the unit and provide ample storage capacity for excess cables. The size of the cutout in the table top varies with each size of Power Matrix unit.

Small

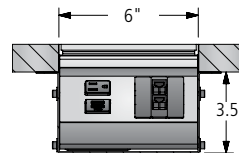
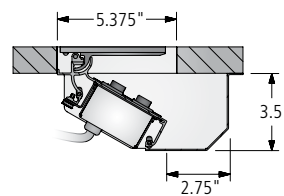

Medium

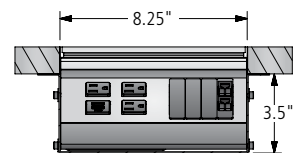
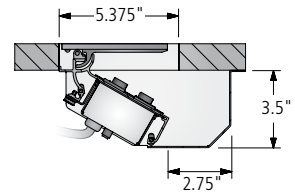

Field Wired

Some local electrical codes may require field-wiring during installation. In such instances, a Field-Wired option may be specified. In this configuration, each Power Matrix unit will be supplied with a 6' flexible metal conduit with hot, ground and neutral wires.

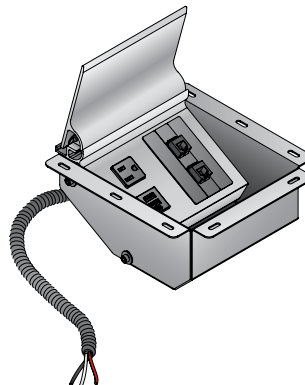

TABLE TOP POWER OPTION: POWER MATRIX

POWER PLANNING

Power Matrix is available with two options for connection with building power:

DIRECT PLUG-IN

The 15-amp power cord from each Power Matrix unit is plugged into a floor monument. The floor monument must have at least one power outlet per small or medium Power Matrix unit in the table (e.g., a table with four small or medium Power Matrix units would need four power outlets in the floor monument).

Direct Plug-In

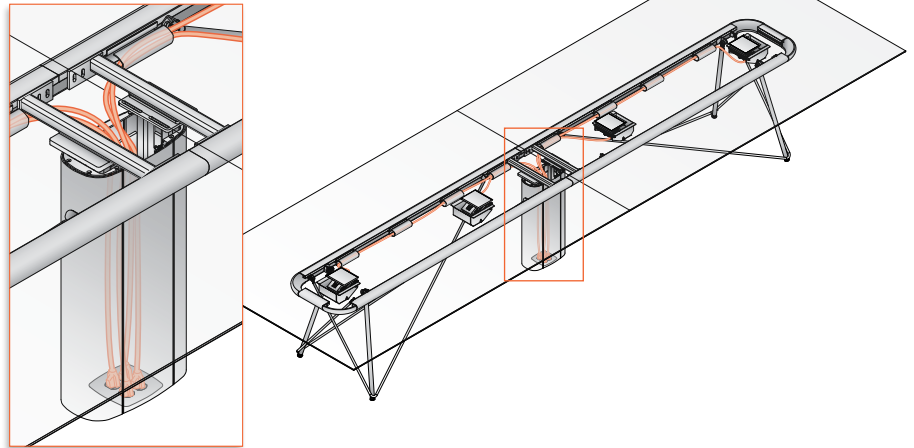

SINGLE IN-FEED

Each Power Matrix unit is plugged into a two-circuit modular electrical system in the table from which a single connection is made to a floor monument. This connection can be either hardwired (to utilize both of the circuits in the modular electrical system) or corded (which requires a 20-amp power outlet in the floor monument and reduces the modular electrical system in the table to a single circuit).

Single Infeed

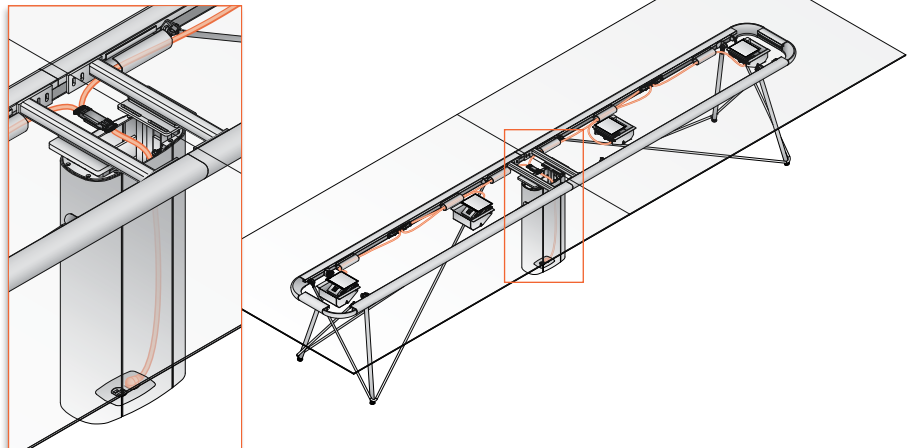

Two-Circuit Modular Electrical System

- 4-wire, 20-amp, 2-circuit modular electrical system
- Only present on tables specified with the Single In-Feed option
- Hardwire or corded (20-amp) in-feed options. A licensed electrician is required to complete hardwire connections to building's power source.
- Neutral (white) wires are 10 gauge, hot and ground wires are 12 gauge
- All electrical components satisfy National Electrical Code (NEC) requirements and are UL listed

Electrical Diagram — Hardwire Power Infeed Only

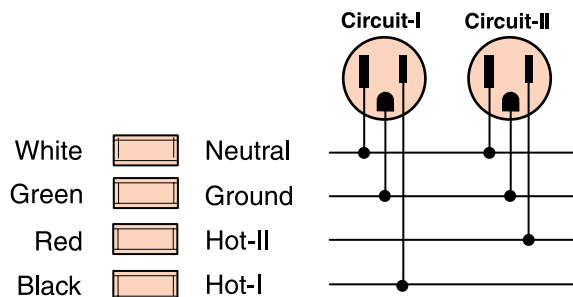



TABLE TOP POWER OPTION: POWER MATRIX

LOCATION CODES

Power Matrix is offered in a variety of locations and quantities per table size, offering a broad range of performance and pricing options.

POWER MATRIX SMALL	POWER MATRIX MEDIUM	LOCATION	QUANTITY OF UNITS TO ORDER
PS-1	PM-1	One at center	1
PS-2	PM-2	One at each end	2
PS-3	PM-3	One at center and one at each end	3
PS-4	PM-4	Four equally spaced	4

DOOR MATERIAL AND LOCATION AVAILABILITY BY TABLE SIZE

W = Wood Door G = Glass Door M = Metal Door

Length	Veneer & Laminate Top Sections	Glass Top Sections	Power Matrix Small				Power Matrix Medium			
			PS-1	PS-2	PS-3	PS-4	PM-1	PM-2	PM-3	PM-4
42	1	1	W/G/M	-	-	-	W/G/M	-	-	-
48	1	1	W/G/M	-	-	-	W/G/M	-	-	-
54	1	1	W/G/M	-	-	-	W/G/M	-	-	-
60	1	1	W/G/M	-	-	-	W/G/M	-	-	-
72	1	1	W/G/M	W/G/M	-	-	W/G/M	W/G/M	-	-
78	1	1	W/G/M	W/G/M	-	-	W/G/M	W/G/M	-	-
84	1	1	W/G/M	W/G/M	-	-	W/G/M	W/G/M	-	-
90	1	1	W/G/M	W/G/M	-	-	W/G/M	W/G/M	-	-
96	1	1	W/G/M	W/G/M	W/G/M	-	W/G/M	W/G/M	W/G/M	-
102	1	2	W/G/M	W/G/M	W/G/M	-	W/G/M	W/G/M	W/G/M	-
102	2	2	-	W/G/M	-	-	-	W/G/M	-	-
108	1	2	W/G/M	W/G/M	W/G/M	-	W/G/M	W/G/M	W/G/M	-
108	2	2	-	W/G/M	-	-	-	W/G/M	-	-
114	1	2	W/G/M	W/G/M	W/G/M	-	W/G/M	W/G/M	W/G/M	-
114	2	2	-	W/G/M	-	-	-	W/G/M	-	-
120	1	2	W/G/M	W/G/M	W/G/M	-	W/G/M	W/G/M	W/G/M	-
120	2	2	-	W/G/M	-	-	-	W/G/M	-	-
132	2	3	-	W/G/M	-	W/G/M	-	W/G/M	-	W/G/M
144	2	3	-	W/G/M	-	W/G/M	-	W/G/M	-	W/G/M
156	2	3	-	W/G/M	-	W/G/M	-	W/G/M	-	W/G/M
168	2	3	-	W/G/M	-	W/G/M	-	W/G/M	-	W/G/M
180	2	3	-	W/G/M	-	W/G/M	-	W/G/M	-	W/G/M
192	2	4	-	W/G/M	-	W/G/M	-	W/G/M	-	W/G/M
192	4	4	-	W/G/M	-	W/G/M	-	W/G/M	-	W/G/M
204	2	4	-	W/G/M	-	W/G/M	-	W/G/M	-	W/G/M
204	4	4	-	W/G/M	-	W/G/M	-	W/G/M	-	W/G/M
216	2	4	-	W/G/M	-	W/G/M	-	W/G/M	-	W/G/M
216	4	4	-	W/G/M	-	W/G/M	-	W/G/M	-	W/G/M
228	2	4	-	W/G/M	-	W/G/M	-	W/G/M	-	W/G/M
228	4	4	-	W/G/M	-	W/G/M	-	W/G/M	-	W/G/M
240	2	4	-	W/G/M	-	W/G/M	-	W/G/M	-	W/G/M
240	4	4	-	W/G/M	-	W/G/M	-	W/G/M	-	W/G/M



TABLE TOP POWER OPTION: POWER MATRIX

POWER MATRIX SMALL OR MEDIUM LOCATION OPTIONS

Please Note: For floor core placement, please reference base location information on page 26.

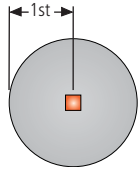

PS-1 or PM-1

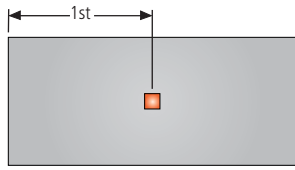

PS-1 or PM-1

PS-1 or PM-1	
Length	Center of Power Matrix
42	21
48	24
54	27
60	30
72	36
78	39
84	42
90	45
96	48
102	51
108	54
114	57
120	60

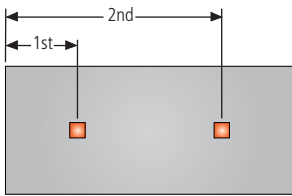

PS-2 or PM-2

PS-2 or PM-2		
Length	Center of 1st Power Matrix	Center of 2nd Power Matrix
72	26	46
78	26	52
84	26	58
90	26	64
96	26	70
102	26	76
108	26	82
114	26	88
120	26	94
132	26	106
144	26	118
156	26	130
168	26	142
180	26	154
192	26	166
204	26	178
216	26	190
228	26	202
240	26	214

TABLE TOP POWER OPTION: POWER MATRIX

POWER MATRIX SMALL OR MEDIUM LOCATION OPTIONS

Please Note: For floor core placement, please reference base location information on page 26.

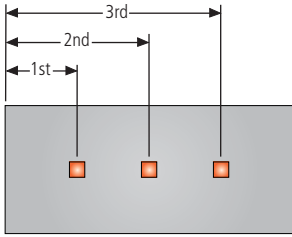

PS-3 or PM-3

PS-3 or PM-3			
Length	Center of 1st Power Matrix	Center of 2nd Power Matrix	Center of 3rd Power Matrix
96	26	48	70
102	26	51	76
108	26	54	82
114	26	57	88
120	26	60	94

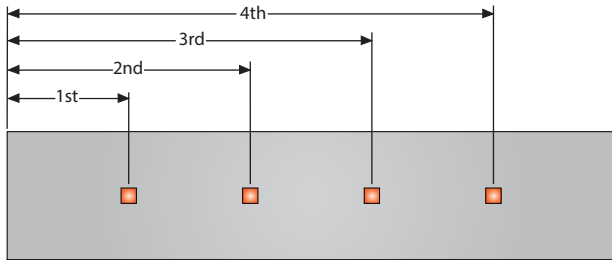

PS-4 or PM-4

PS-4 or PM-4				
Length	Center of 1st Power Matrix	Center of 2nd Power Matrix	Center of 3rd Power Matrix	Center of 4th Power Matrix
132	26	53	79	106
144	26	57	87	118
156	26	61	95	130
168	26	65	103	142
180	26	69	111	154
192	26	73	119	166
204	26	77	127	178
216	26	81	135	190
228	26	85	143	202
240	26	89	151	214



RETRACTORS FOR POWER MATRIX

RETRACTORS

Cable retractors mount directly to the underside of conference room tables using the included mounting bracket. Loaded with 12' of cable that extends out 5' from the retractor. Retractors have a female input from the building infrastructure and a male connector on the output side. Not available on square, round or soft square tables.

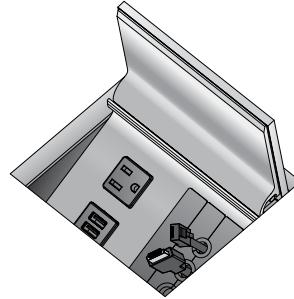

Retractor Wire Management
(Flow table with rectangle bases shown)

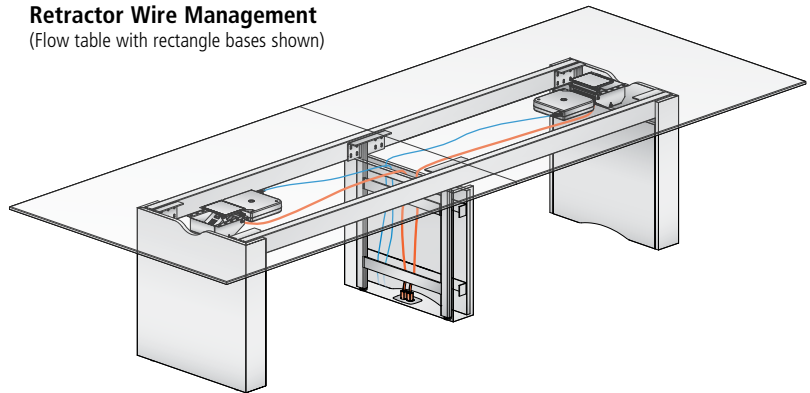

CAT6 Retractor

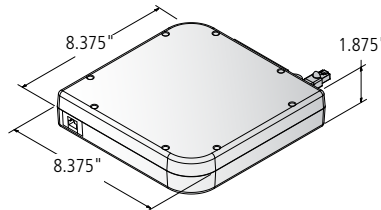

HDMI Retractor

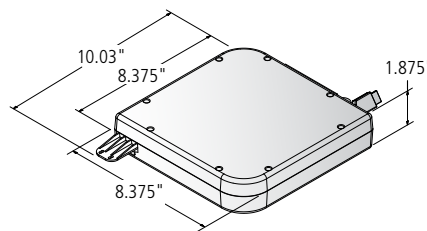

Data USB Retractor

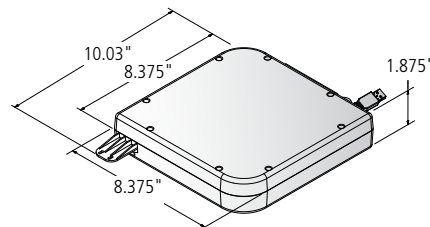



TABLE TOP POWER OPTION: TECH NODE

Tech Node offers convenient access to power and voice/data connections. Tech Node features include a push/push open design that conceals internal components.

Tech Node components:

- Clear or Black Anodized Aluminum
- Fluid one touch accessibility
- Two (2) Simplexes
- Up to two voice/data ports
- 12' 15-Amp cord
- Voice/Data Adapter Kit p/n BE01421 to accept couplers & jacks
- UL Listed
- Overall dimensions - 4-7/16" x 8-5/16"
- Optional powered USB-A+C

All electrical components are UL listed.

Tech Node - Cover Open

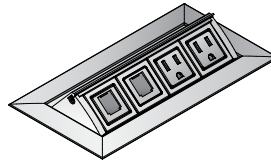

Tech Node - Cover Open with Optional USB-A+C

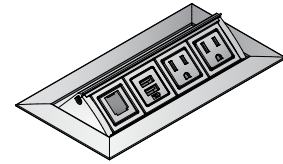

Tech Node - Cover Closed

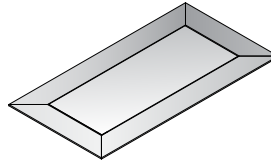

Tech Node - Open Front View

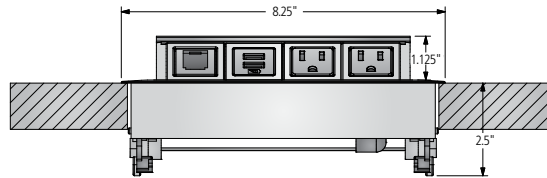

Tech Node - Open Side View

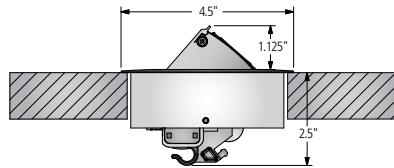

VOICE/DATA PLANNING

Two (2) simplex voice/data cutouts accept customer supplied, field-installed snap-in connectors.

Nucraft recommends consulting an audio/visual (AV) integrator for assistance with voice/data planning.

Voice/Data Product Manufacturers

Manufacturer	Phone Number	Web Site
AMP	1-800-522-6752	www.te.com
Avaya	1-866-462-8292	www.avaya.com
Leviton	1-800-722-2082	www.leviton.com
Panduit	1-800-777-3300	www.panduit.com
Siemon	1-860-945-4200	www.siemon.com



TABLE TOP POWER OPTION: TECH NODE

LOCATION CODES

Location Codes		
Tech Node	Location	Qty of Units to Order
TN-1	One at center	1
TN-2	One at each end	2
TN-3	One at center and one at each end	3
TN-4	Four equally spaced	4

TECH NODE LOCATION OPTIONS

Please Note: For floor core placement, please reference base location information on page 26.

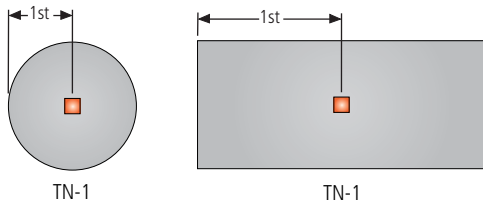

TN-1	
Length	Center of Tech Node
42	21
48	24
54	27
60	30
72	36
78	39
84	42
90	45
96	48
102	51
108	54
114	57
120	60
120	60

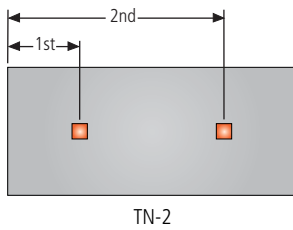

TN-2		
Length	Center of 1st Tech Node	Center of 2nd Tech Node
72	26	46
78	26	52
84	26	58
90	26	64
96	26	70
102	26	76
108	26	82
114	26	88
120	26	94
132	26	106
144	26	118
156	26	130
168	26	142
180	26	154
192	26	166
204	26	178
216	26	190
228	26	202
240	26	214

TABLE TOP POWER OPTION: TECH NODE

TECH NODE LOCATION OPTIONS

Please Note: For floor core placement, please reference base location information on page 26.

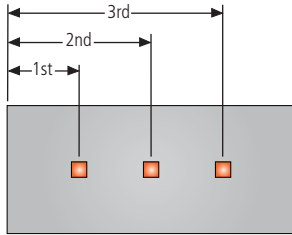

TN-3

TN-3			
Length	Center of 1st Tech Node	Center of 2nd Tech Node	Center of 3rd Tech Node
96	26	48	70
102	26	51	76
108	26	54	82
114	26	57	88
120	26	60	94

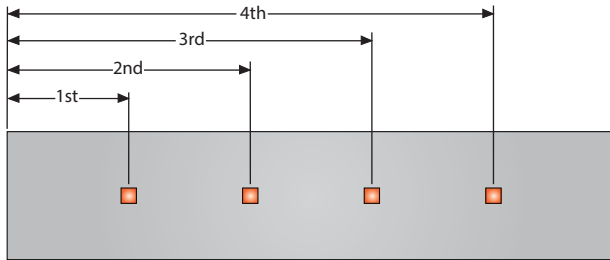

TN-4

TN-4				
Length	Center of 1st Tech Node	Center of 2nd Tech Node	Center of 3rd Tech Node	Center of 4th Tech Node
132	26	53	79	106
144	26	57	87	118
156	26	61	95	130
168	26	65	103	142
180	26	69	111	154
192	26	73	119	166
204	26	77	127	178
216	26	81	135	190
228	26	85	143	202
240	26	89	151	214



TABLE TOP POWER OPTION: POWER SPEC AND USB SPEC

This compact unit allows for the addition of power or data to a work surface in a discreet way. Available in round or square shapes, and multiple finish options.

Power Spec

- Spill-proof power simplex
- Compact design
- 1-3/4" cutout for installation
- UL Listed

Power Spec

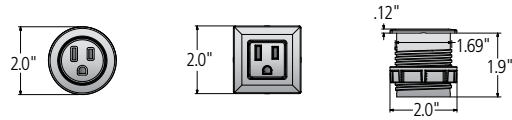

USB Spec

- Used to charge devices or transfer data
- Compact design
- Offered with USB-A+C
- 1-3/4" cutout
- UL Listed

USB Spec

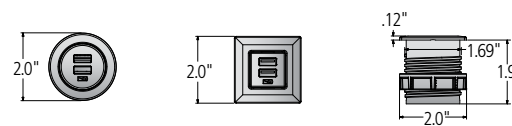



UNDER SURFACE POWER OPTION: POWER RAIL

This low-profile option addresses the need for power & data connectivity just below the table top. This is an ideal choice for those who desire a visually uninterrupted table top and appreciate the inherent flexibility of the Power Rail to be removed at a later date as they transition to a truly wireless environment.

Held in place with screws, Power Rail units can be placed anywhere along the perimeter of the table. This flexible mounting design allows for additional units to be added as necessary, or to be removed when no longer needed.

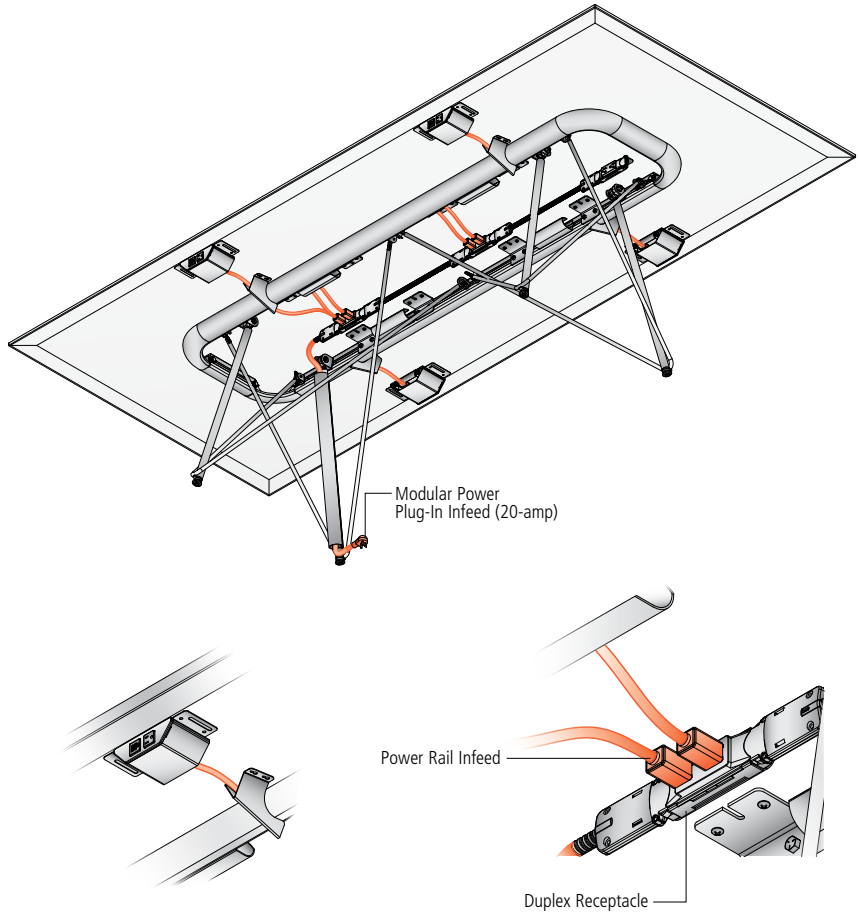

Power Rails are available in three configurations:

- Two simplex receptacles (UL Listed)
- One simplex receptacle and one powered USB-A+C connector (UL Listed)
- Two single space A/V faceplate designed for use with Modular AV Inserts/Plates

When Power Rails are specified on a Baja table, a direct plug-in infeed or hardwired option is available. The direct plug-in infeed option has a single circuit electrical system and the hardwire option requires a two-circuit electrical system. Maximum of 12 Power Rails per table.

Front Elevation

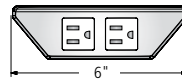

Side Elevation

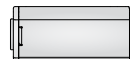
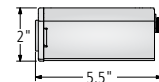



UNDER SURFACE POWER OPTION: CHARGING TRAC

Charging Trac is a low voltage, under surface power system with 2 USB ports per unit. It's modular configuration provides a customizable solution. Offered in a 2 or 4 unit kit of parts with a plug-in infeed. USB-A compatible.

Charging Trac Wire Management

(Flow table with rectangle bases shown)

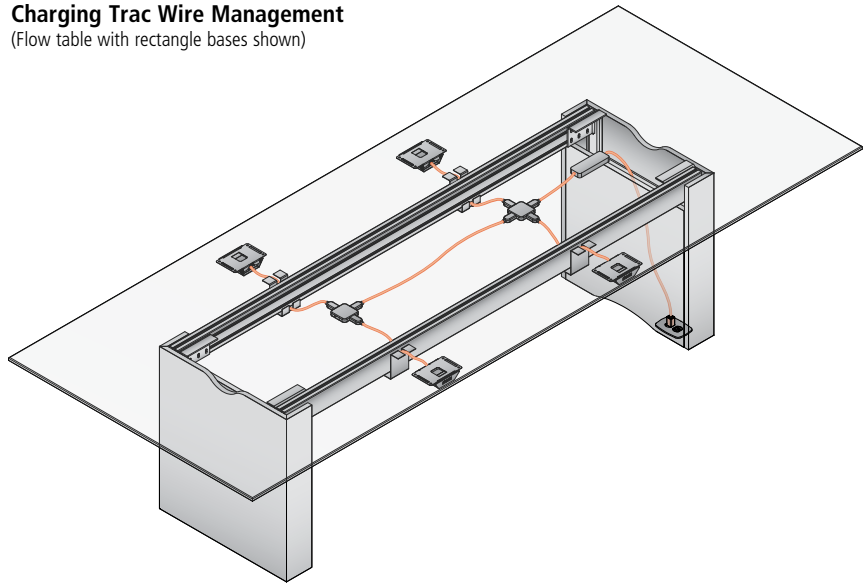

Front Elevation

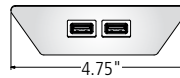

Side Elevation

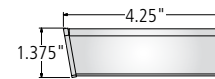

Two-Unit Configuration includes:

- 2 Brackets, each bracket offers 2 USB-A ports
- 1 Puck
- 1 Plug-in infeed

Two-Unit Configuration

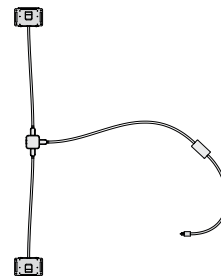

Four-Unit Configuration includes:

- 4 Brackets, each bracket offers 2 USB-A ports
- 2 Pucks
- Jumpers
- 1 Plug-in infeed

Four-Unit Configuration

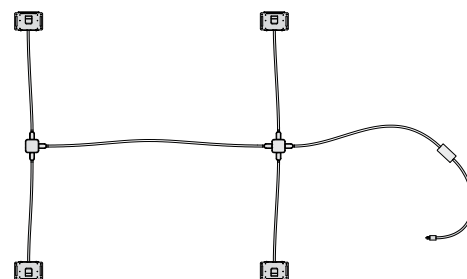



FREESTANDING POWER OPTION: TECH ZONE

TECH ZONE

Simple, easy to use and portable, this freestanding table top power option allows you to easily charge all of your devices.

Available in two configurations with a variety of power and data connectivity options. Includes a 72"-long plug-in infeed cord.

ZONE-USB-C

Includes two simplex receptacles, one data port and one charging USB-A+C charging port

ZONE-DATA

Includes two simplex receptacles and two open data ports

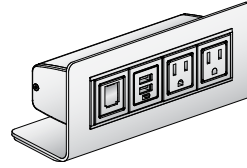

Tech Zone - Side View

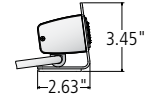

ZONE-USB-C

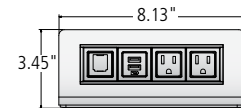

ZONE-DATA

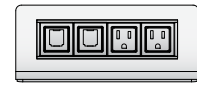



WIRE MANAGEMENT OPENINGS

Wire Frame Base with Wire Manager



Wire management opening is the same for all tables, regardless of top size. Each table includes one wire management channel.

Hoop Base with Wire Manager



Wire management opening is the same for all tables, regardless of top size. Each table includes one wire management channel.

Wire Frame / Hoop Base (Optional Center Column)

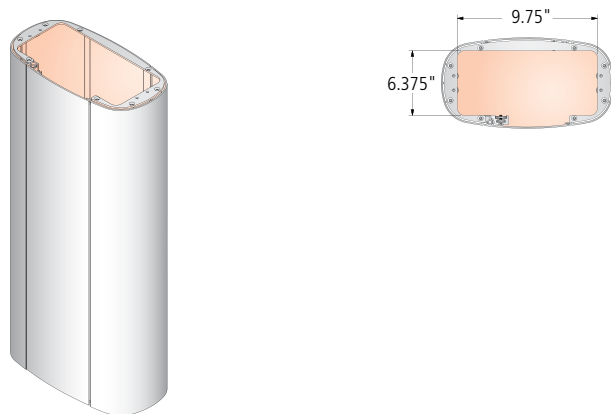

Wire management opening is the same for all tables, regardless of top size



BASE DIMENSIONS

Wire Frame Base - Round, Square and Soft Square Tables

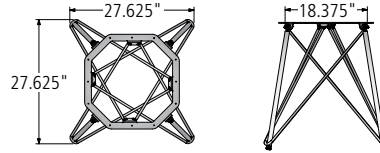
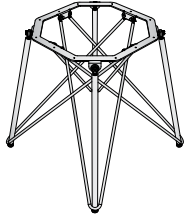

Same size base utilized for all sizes (42"-60") round, square and soft square tables

Wire Frame Base - Rectangle and Soft Rectangle Tables

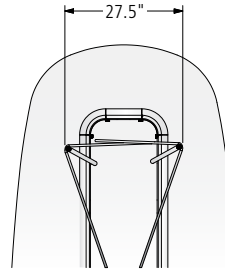
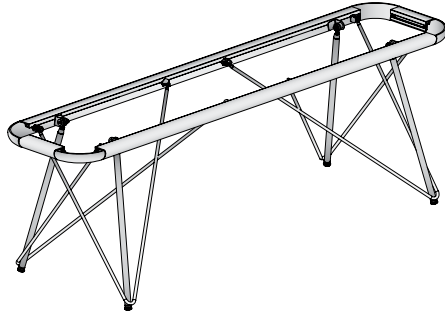

The span between the glides will remain the same for all table sizes

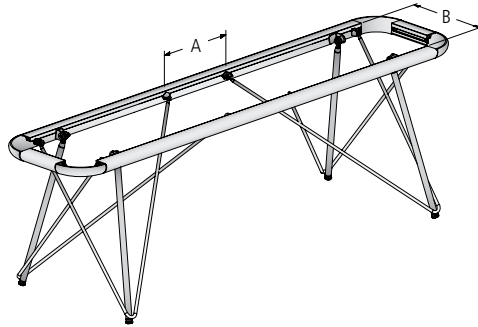
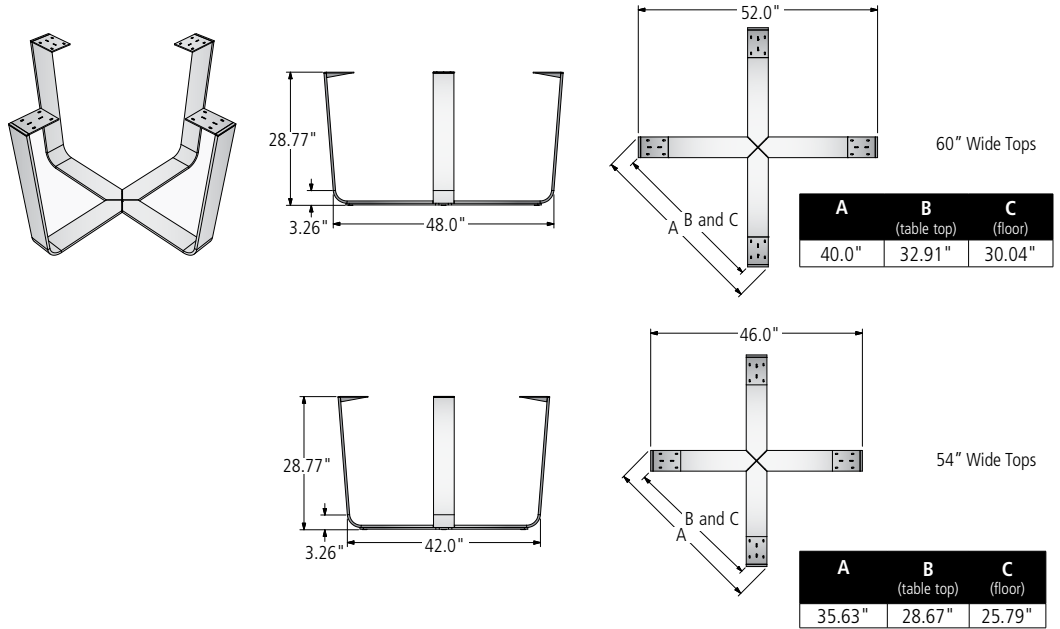

Table Length	A	B
72	2	15-1/2
78	4	15-1/2
84	6	15-1/2
90	2	15-1/2
96	4	15-1/2
102	10	15-1/2
108	2	15-1/2
114	8	15-1/2
120	14	15-1/2
132	2	15-1/2
144	14	15-1/2
156	26	15-1/2
168	2	15-1/2
180	14	15-1/2



BASE DIMENSIONS

Hoop Base - Round, Square and Soft Square Tables



Hoop Base - Rectangle and Soft Rectangle Tables

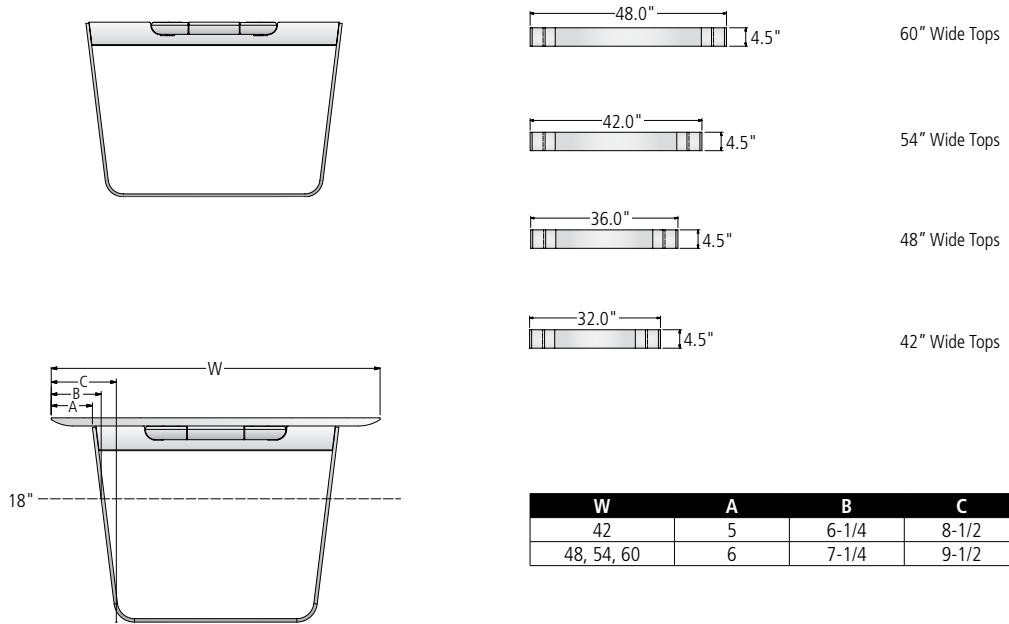

Center Hoop Base - 54" and 60"-Wide Soft Rectangle Tables

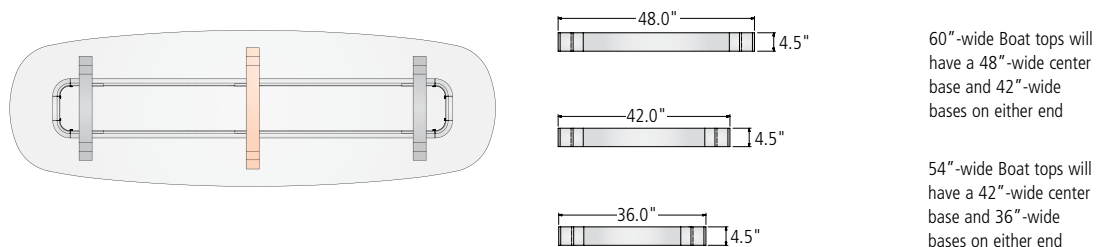



BASE LOCATIONS

Wire Frame (all table shapes)

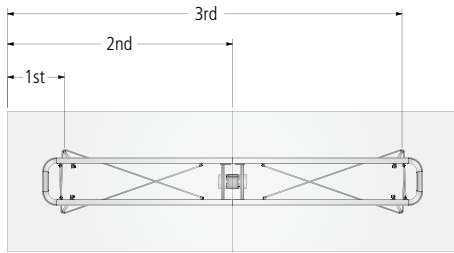

Table Length (inches)	Center of 1st Base	Center of 2nd Base	Center of 3rd Base
72	16	56	-
78	18	60	-
84	20	64	-
90	22	68	-
96	24	72	-
102	24	78	-
108	24	84	-
114	24	90	-
120	24	96	-
132	24	108	-
144	24	120	-
156	24	78	132
168	24	84	144
180	24	90	156
192	24	96	168
204	24	102	180
216	24	108	192
228	24	114	204
240	24	120	216

*Wire Frame will not fit over a floor core.

Hoop Base (all table shapes)

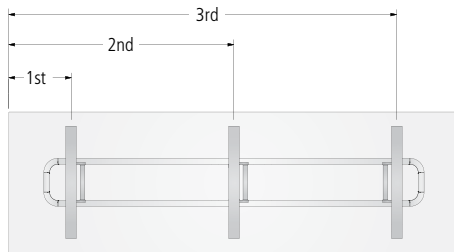

Table Length (inches)	Center of 1st Base	Center of 2nd Base	Center of 3rd Base
72	20.125	51.875	-
78	22.125	55.875	-
84	25.75	58.25	-
90	28.75	61.25	-
96	31.25	64.75	-
102	34.25	67.75	-
108	34.25	73.75	-
114	27.25	86.75	-
120	29.25	90.75	-
132	32.25	99.75	-
144	27.25	116.75	-
156	34.25	78	121.75
168	26	84	142
180	29.25	90	150.75
192	31.25	96	160.75
204	31.25	102	172.75
216	34.25	108	181.75
228	26	114	202
240	29.25	120	210.75

*Hoop Base will not fit over a floor core.



VENEER TOP



ROUND TOP



SOFT SQUARE TOP



SQUARE TOP

EDGE PROFILE / BASE KEY

SURF EDGE PROFILE
SWF Wire Frame

CREST EDGE PROFILE
WF Wire Frame
HP Four Leg Hoop

ROUND TABLES

MODEL #	DIAMETER	TOP SECTIONS	SEATING CAPACITY	-SWF	-WF	-HP
BJR-42-V	42	1	4	9,425	6,757	-
BJR-48-V	48	1	4	11,496	8,114	-
BJR-54-V	54	1	4	-	9,739	8,526
BJR-60-V	60	1	4	-	11,254	9,966

SOFT SQUARE TABLES

MODEL #	L x W	TOP SECTIONS	SEATING CAPACITY	-SWF	-WF	-HP
BJQ-42-V	42 x 42	1	4	9,425	6,757	-
BJQ-48-V	48 x 48	1	4	11,496	8,114	-
BJQ-54-V	54 x 54	1	4	-	9,739	8,526
BJQ-60-V	60 x 60	1	4	-	11,254	9,966

SQUARE TABLES

MODEL #	L x W	TOP SECTIONS	SEATING CAPACITY	-WF	-HP
BJS-42-V	42 x 42	1	4	6,757	-
BJS-48-V	48 x 48	1	4	8,114	-
BJS-54-V	54 x 54	1	4	9,739	8,526
BJS-60-V	60 x 60	1	4	11,254	9,966

OPTIONS

Polished Chrome Base Finish Options:

CODE	PRICE
Wire Frame Base -PCWFS	\$3,558
Hoop Base -PCH4	\$5,648

Blackened Nickel Base Finish Options:

CODE	PRICE
Wire Frame Base -BNWFS	\$1,726
Hoop Base -BNH4	\$5,648

Wire Frame Combination Finish Options:

CODE	PRICE
Polished Chrome Wires with Blackened Nickel Posts -TTS-BN	\$2,757
Polished Chrome Wires with Satin Chrome Posts -TTS-BC	\$2,383
Polished Chrome Wires with Powder Coat Posts -TTS-P	\$1,866

Power and Data Options

See pages 52-61

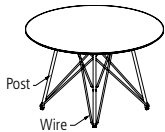

EDGE PROFILES



Surf Edge Profile

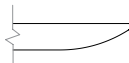

Crest Edge Profile

GENERAL INFORMATION

- Tops are 1-1/8" thick
- Seating capacity based on 27" per person
- Overall table height 29-1/2"
- Standard with flat cut veneer
- If selecting Blackened Nickel base finish, choose Storm for Wire Management color

REQUIRED INFORMATION (ORDER CANNOT BE ENTERED WITHOUT THIS INFORMATION)

- See appendix pages vi-vii for surface material options.
- Choose Veneer Finish
 - Choose Metal Finish. Clear Anodized (-CA) not available



PLANK VENEER TOP



ROUND TOP



SOFT SQUARE TOP



SQUARE TOP

EDGE PROFILE / BASE KEY

SURF EDGE PROFILE
SWF Wire Frame

CREST EDGE PROFILE
WF Wire Frame
HP Four Leg Hoop

ROUND TABLES

MODEL #	DIAMETER	TOP SECTIONS	SEATING CAPACITY	-SWF	-WF	-HP
BJR-42-PW	42	1	4	10,839	7,771	-
BJR-48-PW	48	1	4	13,221	9,332	-
BJR-54-PW	54	1	4	-	11,200	9,805
BJR-60-PW	60	1	4	-	12,943	11,461

SOFT SQUARE TABLES

MODEL #	L x W	TOP SECTIONS	SEATING CAPACITY	-SWF	-WF	-HP
BJQ-42-PW	42 x 42	1	4	10,839	7,771	-
BJQ-48-PW	48 x 48	1	4	13,221	9,332	-
BJQ-54-PW	54 x 54	1	4	-	11,200	9,805
BJQ-60-PW	60 x 60	1	4	-	12,943	11,461

SQUARE TABLES

MODEL #	L x W	TOP SECTIONS	SEATING CAPACITY	-WF	-HP
BJS-42-PW	42 x 42	1	4	7,771	-
BJS-48-PW	48 x 48	1	4	9,332	-
BJS-54-PW	54 x 54	1	4	11,200	9,805
BJS-60-PW	60 x 60	1	4	12,943	11,461

OPTIONS

OPTIONS	CODE	PRICE	NOTES
Polished Chrome Base Finish Options:			
Wire Frame Base	-PCWFS	\$3,558	
Hoop Base	-PCH4	\$5,648	
Blackened Nickel Base Finish Options:			
Wire Frame Base	-BNWFS	\$1,726	
Hoop Base	-BNH4	\$5,648	
Wire Frame Combination Finish Options:			
Polished Chrome Wires with Blackened Nickel Posts	-TTS-BN	\$2,757	
Polished Chrome Wires with Satin Chrome Posts	-TTS-BC	\$2,383	
Polished Chrome Wires with Powder Coat Posts	-TTS-P	\$1,866	
Power and Data Options			See pages 52-61

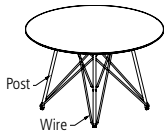

EDGE PROFILES



Surf Edge Profile



Crest Edge Profile

GENERAL INFORMATION

- Tops are 1-1/8" thick
- Seating capacity based on 27" per person
- Overall table height 29-1/2"
- Standard with flat cut veneer
- If selecting Blackened Nickel base finish, choose Storm for Wire Management color

REQUIRED INFORMATION (ORDER CANNOT BE ENTERED WITHOUT THIS INFORMATION)

- See appendix pages vi-vii for surface material options.
- Choose Metal Finish. Clear Anodized (-CA) not available



LAMINATE TOP WITH SQUARE EDGE

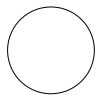

ROUND TOP

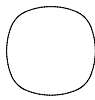

SOFT SQUARE TOP



SQUARE TOP

EDGE PROFILE / BASE KEY

CREST EDGE PROFILE
 WF Wire Frame
 HP Four Leg Hoop

ROUND TABLES

MODEL #	DIAMETER	TOP SECTIONS	SEATING CAPACITY	-WF	-HP
BJR-42-PA	42	1	4	6,082	-
BJR-48-PA	48	1	4	7,303	-
BJR-54-PA	54	1	4	8,766	7,674
BJR-60-PA	60	1	4	10,129	8,970

SOFT SQUARE TABLES

MODEL #	L x W	TOP SECTIONS	SEATING CAPACITY	-WF	-HP
BJQ-42-PA	42 x 42	1	4	6,082	-
BJQ-48-PA	48 x 48	1	4	7,303	-
BJQ-54-PA	54 x 54	1	4	8,766	7,674
BJQ-60-PA	60 x 60	1	4	10,129	8,970

SQUARE TABLES

MODEL #	L x W	TOP SECTIONS	SEATING CAPACITY	-WF	-HP
BJS-42-PA	42 x 42	1	4	6,082	-
BJS-48-PA	48 x 48	1	4	7,303	-
BJS-54-PA	54 x 54	1	4	8,766	7,674
BJS-60-PA	60 x 60	1	4	10,129	8,970

OPTIONS

OPTIONS	CODE	PRICE	NOTES
Polished Chrome Base Finish Options:			
Wire Frame Base	-PCWFS	\$3,558	
Hoop Base	-PCH4	\$5,648	
Blackened Nickel Base Finish Options:			
Wire Frame Base	-BNWFS	\$1,726	
Hoop Base	-BNH4	\$5,648	
Wire Frame Combination Finish Options:			
Polished Chrome Wires with Blackened Nickel Posts	-TTS-BN	\$2,757	
Polished Chrome Wires with Satin Chrome Posts	-TTS-BC	\$2,383	
Polished Chrome Wires with Powder Coat Posts	-TTS-P	\$1,866	
Power and Data Options			See pages 52-61

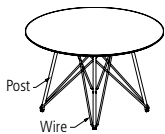

EDGE PROFILE



Crest Edge Profile

GENERAL INFORMATION

- Tops are 1-1/8" thick
- Seating capacity based on 27" per person
- Overall table height 29-1/2"
- If selecting Blackened Nickel base finish, choose Storm for Wire Management color

REQUIRED INFORMATION (ORDER CANNOT BE ENTERED WITHOUT THIS INFORMATION)

See appendix pages vi-vii for surface material options.

- Choose Laminate
- Choose Edge Band Finish
- Choose Metal Finish. Clear Anodized (-CA) not available.



INSET LAMINATE TOP WITH HARDWOOD EDGE



ROUND TOP



SOFT SQUARE TOP



SQUARE TOP

EDGE PROFILE / BASE KEY

CREST EDGE PROFILE
 WF Wire Frame
 HP Four Leg Hoop

ROUND TABLES

MODEL #	DIAMETER	TOP SECTIONS	SEATING CAPACITY	-WF	-HP
BJR-42-P	42	1	4	6,082	-
BJR-48-P	48	1	4	7,303	-
BJR-54-P	54	1	4	8,766	7,674
BJR-60-P	60	1	4	10,129	8,970

SOFT SQUARE TABLES

MODEL #	L x W	TOP SECTIONS	SEATING CAPACITY	-WF	-HP
BJQ-42-P	42 x 42	1	4	6,082	-
BJQ-48-P	48 x 48	1	4	7,303	-
BJQ-54-P	54 x 54	1	4	8,766	7,674
BJQ-60-P	60 x 60	1	4	10,129	8,970

SQUARE TABLES

MODEL #	L x W	TOP SECTIONS	SEATING CAPACITY	-WF	-HP
BJS-42-P	42 x 42	1	4	6,082	-
BJS-48-P	48 x 48	1	4	7,303	-
BJS-54-P	54 x 54	1	4	8,766	7,674
BJS-60-P	60 x 60	1	4	10,129	8,970

OPTIONS

OPTIONS	CODE	PRICE	NOTES
Polished Chrome Base Finish Options:			
Wire Frame Base	-PCWFS	\$3,558	
Hoop Base	-PCH4	\$5,648	
Blackened Nickel Base Finish Options:			
Wire Frame Base	-BNWFS	\$1,726	
Hoop Base	-BNH4	\$5,648	
Wire Frame Combination Finish Options:			
Polished Chrome Wires with Blackened Nickel Posts	-TTS-BN	\$2,757	
Polished Chrome Wires with Satin Chrome Posts	-TTS-BC	\$2,383	
Polished Chrome Wires with Powder Coat Posts	-TTS-P	\$1,866	
Power and Data Options			See pages 52-61

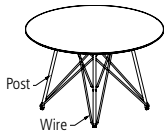

EDGE PROFILE

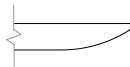

Crest Edge Profile

GENERAL INFORMATION

- Tops are 1-1/8" thick
- Seating capacity based on 27" per person
- Overall table height 29-1/2"
- If selecting Blackened Nickel base finish, choose Storm for Wire Management color

REQUIRED INFORMATION (ORDER CANNOT BE ENTERED WITHOUT THIS INFORMATION)

- See appendix pages vi-vii for surface material options.
- Choose Laminate
 - Choose Veneer Finish
 - Choose Metal Finish. Clear Anodized (-CA) not available.



GLASS TOP



ROUND TOP



SOFT SQUARE TOP



SQUARE TOP

EDGE PROFILE / BASE KEY

GLASS EDGE PROFILE
 WF Wire Frame
 HP Four Leg Hoop

ROUND TABLES

MODEL #	DIAMETER	TOP SECTIONS	SEATING CAPACITY	-WF	-HP
BJR-42-G	42	1	4	9,425	-
BJR-48-G	48	1	4	11,496	-
BJR-54-G	54	1	4	14,003	12,790
BJR-60-G	60	1	4	16,407	15,119

SOFT SQUARE TABLES

MODEL #	L x W	TOP SECTIONS	SEATING CAPACITY	-WF	-HP
BJQ-42-G	42 x 42	1	4	9,425	-
BJQ-48-G	48 x 48	1	4	11,496	-
BJQ-54-G	54 x 54	1	4	14,003	12,790
BJQ-60-G	60 x 60	1	4	16,407	15,119

SQUARE TABLES

MODEL #	L x W	TOP SECTIONS	SEATING CAPACITY	-WF	-HP
BJS-42-G	42 x 42	1	4	9,425	-
BJS-48-G	48 x 48	1	4	11,496	-
BJS-54-G	54 x 54	1	4	14,003	12,790
BJS-60-G	60 x 60	1	4	16,407	15,119

OPTIONS

OPTIONS	CODE	PRICE	NOTES
Polished Chrome Base Finish Options:			
Wire Frame Base	-PCWFS	\$3,558	
Hoop Base	-PCH4	\$5,648	
Blackened Nickel Base Finish Options:			
Wire Frame Base	-BNWFS	\$1,726	
Hoop Base	-BNH4	\$5,648	
Wire Frame Combination Finish Options:			
Polished Chrome Wires with Blackened Nickel Posts	-TTS-BN	\$2,757	
Polished Chrome Wires with Satin Chrome Posts	-TTS-BC	\$2,383	
Polished Chrome Wires with Powder Coat Posts	-TTS-P	\$1,866	
Satin Glass	Add -RSG	\$430	
Power and Data Options			See pages 52-61

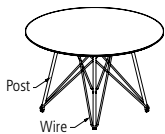

EDGE PROFILE

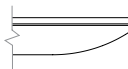

Glass Edge Profile

GENERAL INFORMATION

- Tops include a 1-1/8" thick sub-top with 3/16" deep hardwood edge band and 1/4" thick back-painted, low iron glass
- Seating capacity based on 27" per person
- Overall table height 29-1/2"
- Unless otherwise specified, the sub-top finish will match the base finish, if Polished Chrome finish is specified for the base, the sub-top finish will be Foil
- If selecting Blackened Nickel base finish, choose Storm for Wire Management color

REQUIRED INFORMATION (ORDER CANNOT BE ENTERED WITHOUT THIS INFORMATION)

- See appendix pages vi-vii for surface material options.
- Choose Glass Finish
 - Choose Paint Sub-Top Finish
 - Choose Metal Finish. Clear Anodized (-CA) not available



VENEER TOP

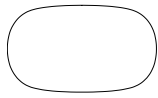

SOFT RECTANGLE TOP

EDGE PROFILE / BASE KEY

SURF EDGE PROFILE
 SWF Wire Frame
 SHP Hoop Base

CREST EDGE PROFILE
 WF Wire Frame
 HP Hoop Base

SOFT RECTANGLE TABLES

MODEL #	L x W	TOP SECTIONS	BASE QTY	WIRE FRAME SEATING CAPACITY	HOOP BASE SEATING CAPACITY	-SWF	-SHP	-WF	-HP
BJF-7242-V	72 x 42	1	2	6	4	12,741	11,244	9,692	8,195
BJF-7842-V	78 x 42	1	2	6	4	14,062	12,461	10,638	9,037
BJF-8442-V	84 x 42	1	2	8	6	14,498	12,897	10,911	9,310
BJF-8448-V	84 x 48	1	2	8	8	15,827	14,170	11,781	10,124
BJF-9042-V	90 x 42	1	2	8	6	15,709	14,025	11,765	10,081
BJF-9048-V	90 x 48	1	2	8	8	17,186	15,443	12,727	10,984
BJF-9642-V	96 x 42	1	2	8	8	16,168	14,484	12,053	10,369
BJF-9648-V	96 x 48	1	2	8	8	17,723	15,981	13,061	11,319
BJF-10242-V	102 x 42	1	2	8	8	17,551	15,773	13,026	11,248
BJF-10248-V	102 x 48	1	2	8	8	19,273	17,434	14,140	12,301
BJF-10842-V	108 x 42	1	2	10	8	18,035	16,257	13,330	11,552
BJF-10848-V	108 x 48	1	2	10	8	19,841	18,002	14,493	12,654
BJF-11442-V	114 x 42	1	2	10	8	19,494	17,622	14,351	12,479
BJF-11448-V	114 x 48	1	2	10	10	21,482	19,546	15,628	13,692
BJF-12042-V	120 x 42	1	2	10	10	20,003	18,131	14,671	12,799
BJF-12048-V	120 x 48	1	2	10	10	22,077	20,141	15,999	14,063
BJF-12054-V	120 x 54	1	2	12	10	-	-	17,569	15,547
BJF-13248-V	132 x 48	2	2	10	10	-	-	17,440	15,424
BJF-13254-V	132 x 54	2	2	12	10	-	-	19,200	17,094
BJF-14448-V	144 x 48	2	2	12	12	-	-	18,943	16,846
BJF-14454-V	144 x 54	2	2	14	12	-	-	20,902	18,711
BJF-14460-V	144 x 60	2	2	14	12	-	-	23,191	20,884
BJF-15654-V	156 x 54	2	3	14	10	-	-	26,850	23,530
BJF-15660-V	156 x 60	2	3	14	10	-	-	29,566	26,070
BJF-16854-V	168 x 54	2	3	16	10	-	-	27,891	24,572
BJF-16860-V	168 x 60	2	3	16	10	-	-	30,761	27,265
BJF-18054-V	180 x 54	2	3	16	14	-	-	28,932	25,612
BJF-18060-V	180 x 60	2	3	16	14	-	-	31,957	28,461
BJF-19254-V	192 x 54	2	3	18	14	-	-	29,973	26,654
BJF-19260-V	192 x 60	2	3	18	14	-	-	33,152	29,656
BJF-20454-V	204 x 54	2	3	18	14	-	-	32,273	28,819
BJF-20460-V	204 x 60	2	3	18	14	-	-	35,742	32,104
BJF-21654-V	216 x 54	2	3	20	14	-	-	34,170	30,632
BJF-21660-V	216 x 60	2	3	20	14	-	-	37,888	34,161
BJF-22854-V	228 x 54	2	3	20	18	-	-	35,616	32,044
BJF-22860-V	228 x 60	2	3	20	18	-	-	39,536	35,774
BJF-24054-V	240 x 54	2	3	20	18	-	-	37,152	33,539
BJF-24060-V	240 x 60	2	3	20	18	-	-	41,285	37,480



VENEER TOP

OPTIONS	CODE	PRICE	NOTES
Polished Chrome Base Finish Options:			
(2) Hoop Bases	-PCH2	\$4,675	
(3) Hoop Bases	-PCH3	\$7,012	
Wire Frame Base 72"-132"	-PCWFR-1	\$2,924	
Wire Frame Base 144"-240"	-PCWFR-2	\$4,869	
Blackened Nickel Base Finish Options:			
(2) Hoop Bases	-BNH2	\$4,675	
(3) Hoop Bases	-BNH3	\$7,012	
Wire Frame Base 72"-132"	-BNWFR-1	\$2,924	
Wire Frame Base 144"-240"	-BNWFR-2	\$4,869	
Wire Frame Combination Finish Options:			
Polished Chrome Wires with Blackened Nickel Posts	-TTR-BN	\$3,033	
Polished Chrome Wires with Satin Chrome Posts	-TTR-BC	\$3,174	
Polished Chrome Wires with Powder Coat Posts	-TTR-P	\$2,804	
Center Column Finish Options:			
Polished Chrome Center Column Base	-PCCB	\$1,561	
Powder Coat Center Column Base*	-BRP	No Charge	Replaces existing middle base on Hoop Base
*When specifying -BRP in conjunction with a Polished Chrome finish on Hoop Base tables with 3 bases, use the upcharge code and pricing for 2 base tables (-PCH2)			
Multi-Section Tops:			
102", 108", 114" and 120" one-piece tops split into two sections	Specify -2**	\$1,006	
204", 216", 228" or 240" two-piece tops split into four sections	Specify -4	\$2,010	
**Note: Two-Piece top option not available with surf edge profile. Also, Power Matrix (center of table location only) cannot be specified with this option.			
Power and Data Options			See pages 52-61

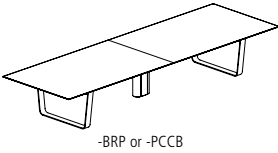
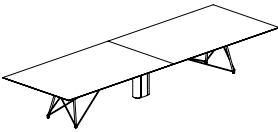
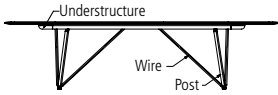

EDGE PROFILES

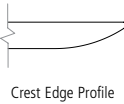
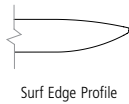

GENERAL INFORMATION

- Tops are 1-1/8" thick
- Seating capacity based on 27" per person
- Overall table height 29.5"
- Tables with three Hoop bases will default to three of the same base. If an alternate center base is needed, specify the -BRP or -PCCB Center Column Base option above.
- Wire Frame base tables 156" or longer include a center column in the same finish as the base. When the Wire Frame base is polished chrome, the center column base will default to Foil. When blackened nickel is specified, the center column base will default to Storm. When specified with the combination finish option, the center column base finish will need to be specified.
- Standard with flat cut veneer
- When Hoop Base or Wire Frame Base is specified in Polished Chrome, the support rails for the table will default to Black
- If selecting Blackened Nickel base finish, choose Storm for Wire Management color

REQUIRED INFORMATION (ORDER CANNOT BE ENTERED WITHOUT THIS INFORMATION)

- See appendix pages vi-vii for surface material options.
- Choose Veneer Finish
 - Choose Metal Finish. Clear Anodized (-CA) not available



VENEER TOP



RECTANGLE TOP

EDGE PROFILE / BASE KEY

CREST EDGE PROFILE
 WF Wire Frame
 HP Hoop Base

RECTANGLE TABLES

MODEL #	L x W	TOP SECTIONS	BASE QTY	WIRE FRAME SEATING CAPACITY	HOOP BASE SEATING CAPACITY	-WF	-HP
BJT-7242-V	72 x 42	1	2	6	4	9,692	8,195
BJT-7842-V	78 x 42	1	2	6	4	10,638	9,037
BJT-8442-V	84 x 42	1	2	8	6	10,911	9,310
BJT-8448-V	84 x 48	1	2	8	8	11,781	10,124
BJT-9042-V	90 x 42	1	2	8	6	11,765	10,081
BJT-9048-V	90 x 48	1	2	8	8	12,727	10,984
BJT-9642-V	96 x 42	1	2	8	8	12,053	10,369
BJT-9648-V	96 x 48	1	2	8	8	13,061	11,319
BJT-10242-V	102 x 42	1	2	8	8	13,026	11,248
BJT-10248-V	102 x 48	1	2	8	8	14,140	12,301
BJT-10842-V	108 x 42	1	2	10	8	13,330	11,552
BJT-10848-V	108 x 48	1	2	10	8	14,493	12,654
BJT-11442-V	114 x 42	1	2	10	8	14,351	12,479
BJT-11448-V	114 x 48	1	2	10	10	15,628	13,692
BJT-12042-V	120 x 42	1	2	10	10	14,671	12,799
BJT-12048-V	120 x 48	1	2	10	10	15,999	14,063
BJT-12054-V	120 x 54	1	2	12	10	17,569	15,547
BJT-13248-V	132 x 48	2	2	10	10	17,440	15,424
BJT-13254-V	132 x 54	2	2	12	10	19,200	17,094
BJT-14448-V	144 x 48	2	2	12	12	18,943	16,846
BJT-14454-V	144 x 54	2	2	14	12	20,902	18,711
BJT-14460-V	144 x 60	2	2	14	12	23,191	20,884
BJT-15654-V	156 x 54	2	3	14	10	26,850	23,530
BJT-15660-V	156 x 60	2	3	14	10	29,566	26,070
BJT-16854-V	168 x 54	2	3	16	10	27,891	24,572
BJT-16860-V	168 x 60	2	3	16	10	30,761	27,265
BJT-18054-V	180 x 54	2	3	16	14	28,932	25,612
BJT-18060-V	180 x 60	2	3	16	14	31,957	28,461
BJT-19254-V	192 x 54	2	3	18	14	29,973	26,654
BJT-19260-V	192 x 60	2	3	18	14	33,152	29,656
BJT-20454-V	204 x 54	2	3	18	14	32,273	28,819
BJT-20460-V	204 x 60	2	3	18	14	35,742	32,104
BJT-21654-V	216 x 54	2	3	20	14	34,170	30,632
BJT-21660-V	216 x 60	2	3	20	14	37,888	34,161
BJT-22854-V	228 x 54	2	3	20	18	35,616	32,044
BJT-22860-V	228 x 60	2	3	20	18	39,536	35,774
BJT-24054-V	240 x 54	2	3	20	18	37,152	33,539
BJT-24060-V	240 x 60	2	3	20	18	41,285	37,480



VENEER TOP

OPTIONS	CODE	PRICE	NOTES
Polished Chrome Base Finish Options:			
(2) Hoop Bases	-PCH2	\$4,675	
(3) Hoop Bases	-PCH3	\$7,012	
Wire Frame Base 72"-132"	-PCWFR-1	\$2,924	
Wire Frame Base 144"-240"	-PCWFR-2	\$4,869	
Blackened Nickel Base Finish Options:			
(2) Hoop Bases	-BNH2	\$4,675	
(3) Hoop Bases	-BNH3	\$7,012	
Wire Frame Base 72"-132"	-BNWFR-1	\$2,924	
Wire Frame Base 144"-240"	-BNWFR-2	\$4,869	
Wire Frame Combination Finish Options:			
Polished Chrome Wires with Blackened Nickel Posts	-TTR-BN	\$3,033	
Polished Chrome Wires with Satin Chrome Posts	-TTR-BC	\$3,174	
Polished Chrome Wires with Powder Coat Posts	-TTR-P	\$2,804	
Center Column Finish Options:			
Polished Chrome Center Column Base	-PCCB	\$1,561	
Powder Coat Center Column Base*	-BRP	No Charge	Replaces existing middle base on Hoop Base
*When specifying -BRP in conjunction with a Polished Chrome finish on Hoop Base tables with 3 bases, use the upcharge code and pricing for 2 base tables (-PCH2)			
Multi-Section Tops:			
102", 108", 114" and 120" one-piece tops split into two sections	Specify -2**	\$1,006	
204", 216", 228" or 240" two-piece tops split into four sections	Specify -4	\$2,010	
**Note: Two-Piece top option not available with surf edge profile. Also, Power Matrix (center of table location only) cannot be specified with this option.			
Power and Data Options			See pages 52-61

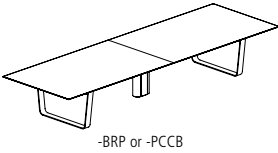
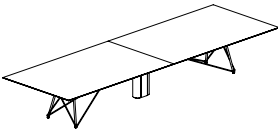
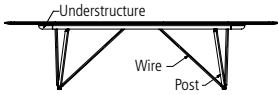

EDGE PROFILE

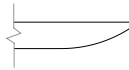

Crest Edge Profile

GENERAL INFORMATION

- Tops are 1-1/8" thick
- Seating capacity based on 27" per person
- Overall table height 29.5"
- Tables with three Hoop bases will default to three of the same base. If an alternate center base is needed, specify the -BRP or -PCCB Center Column Base option above.
- Wire Frame base tables 156" or longer include a center column in the same finish as the base. When the Wire Frame base is polished chrome, the center column base will default to Foil. When blackened nickel is specified, the center column base will default to Storm. When specified with the combination finish option, the center column base finish will need to be specified.
- Standard with flat cut veneer
- When Hoop Base or Wire Frame Base is specified in Polished Chrome, the support rails for the table will default to Black
- If selecting Blackened Nickel base finish, choose Storm for Wire Management color

REQUIRED INFORMATION (ORDER CANNOT BE ENTERED WITHOUT THIS INFORMATION)

See appendix pages vi-vii for surface material options.

- Choose Veneer Finish
- Choose Metal Finish



PLANK VENEER TOP

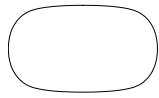

SOFT RECTANGLE TOP

EDGE PROFILE / BASE KEY

SURF EDGE PROFILE
 SWF Wire Frame
 SHP Hoop Base

CREST EDGE PROFILE
 WF Wire Frame
 HP Hoop Base

SOFT RECTANGLE TABLES

MODEL #	L x W	TOP SECTIONS	BASE QTY	WIRE FRAME SEATING CAPACITY	HOOP BASE SEATING CAPACITY	-SWF	-SHP	-WF	-HP
BJF-7242-PW	72 x 42	1	2	6	4	14,653	12,931	11,146	9,425
BJF-7842-PW	78 x 42	1	2	6	4	16,172	14,331	12,234	10,393
BJF-8442-PW	84 x 42	1	2	8	6	16,673	14,832	12,548	10,707
BJF-8448-PW	84 x 48	1	2	8	8	18,202	16,296	13,549	11,643
BJF-9042-PW	90 x 42	1	2	8	6	18,066	16,129	13,530	11,594
BJF-9048-PW	90 x 48	1	2	8	8	19,764	17,760	14,637	12,632
BJF-9642-PW	96 x 42	1	2	8	8	18,594	16,657	13,861	11,925
BJF-9648-PW	96 x 48	1	2	8	8	20,382	18,379	15,021	13,017
BJF-10242-PW	102 x 42	1	2	8	8	20,184	18,139	14,980	12,936
BJF-10248-PW	102 x 48	1	2	8	8	22,164	20,050	16,261	14,147
BJF-10842-PW	108 x 42	1	2	10	8	20,741	18,696	15,330	13,285
BJF-10848-PW	108 x 48	1	2	10	8	22,818	20,703	16,667	14,553
BJF-11442-PW	114 x 42	1	2	10	8	22,419	20,266	16,504	14,351
BJF-11448-PW	114 x 48	1	2	10	10	24,705	22,478	17,973	15,746
BJF-12042-PW	120 x 42	1	2	10	10	23,004	20,851	16,872	14,719
BJF-12048-PW	120 x 48	1	2	10	10	25,389	23,163	18,399	16,173
BJF-12054-PW	120 x 54	1	2	12	10	-	-	20,205	17,880
BJF-13248-PW	132 x 48	2	2	10	10	-	-	20,056	17,738
BJF-13254-PW	132 x 54	2	2	12	10	-	-	22,080	19,659
BJF-14448-PW	144 x 48	2	2	12	12	-	-	21,785	19,373
BJF-14454-PW	144 x 54	2	2	14	12	-	-	24,038	21,518
BJF-14460-PW	144 x 60	2	2	14	12	-	-	26,670	24,017
BJF-15654-PW	156 x 54	2	3	14	10	-	-	30,878	27,060
BJF-15660-PW	156 x 60	2	3	14	10	-	-	34,001	29,981
BJF-16854-PW	168 x 54	2	3	16	10	-	-	32,075	28,258
BJF-16860-PW	168 x 60	2	3	16	10	-	-	35,376	31,355
BJF-18054-PW	180 x 54	2	3	16	14	-	-	33,272	29,454
BJF-18060-PW	180 x 60	2	3	16	14	-	-	36,751	32,731
BJF-19254-PW	192 x 54	2	3	18	14	-	-	34,469	30,653
BJF-19260-PW	192 x 60	2	3	18	14	-	-	38,125	34,105
BJF-20454-PW	204 x 54	2	3	18	14	-	-	37,114	33,142
BJF-20460-PW	204 x 60	2	3	18	14	-	-	41,104	36,920
BJF-21654-PW	216 x 54	2	3	20	14	-	-	39,296	35,227
BJF-21660-PW	216 x 60	2	3	20	14	-	-	43,572	39,286
BJF-22854-PW	228 x 54	2	3	20	18	-	-	40,959	36,851
BJF-22860-PW	228 x 60	2	3	20	18	-	-	45,467	41,141
BJF-24054-PW	240 x 54	2	3	20	18	-	-	42,725	38,570
BJF-24060-PW	240 x 60	2	3	20	18	-	-	47,478	43,102



PLANK VENEER TOP

OPTIONS	CODE	PRICE	NOTES
Polished Chrome Base Finish Options:			
(2) Hoop Bases	-PCH2	\$4,675	
(3) Hoop Bases	-PCH3	\$7,012	
Wire Frame Base 72"-132"	-PCWFR-1	\$2,924	
Wire Frame Base 144"-240"	-PCWFR-2	\$4,869	
Blackened Nickel Base Finish Options:			
(2) Hoop Bases	-BNH2	\$4,675	
(3) Hoop Bases	-BNH3	\$7,012	
Wire Frame Base 72"-132"	-BNWFR-1	\$2,924	
Wire Frame Base 144"-240"	-BNWFR-2	\$4,869	
Wire Frame Combination Finish Options:			
Polished Chrome Wires with Blackened Nickel Posts	-TTR-BN	\$3,033	
Polished Chrome Wires with Satin Chrome Posts	-TTR-BC	\$3,174	
Polished Chrome Wires with Powder Coat Posts	-TTR-P	\$2,804	
Center Column Finish Options:			
Polished Chrome Center Column Base	-PCCB	\$1,561	
Powder Coat Center Column Base*	-BRP	No Charge	Replaces existing middle base on Hoop Base
*When specifying -BRP in conjunction with a Polished Chrome finish on Hoop Base tables with 3 bases, use the upcharge code and pricing for 2 base tables (-PCH2)			
Multi-Section Tops:			
102", 108", 114" and 120" one-piece tops split into two sections	Specify -2**	\$1,006	
204", 216", 228" or 240" two-piece tops split into four sections	Specify -4	\$2,010	
**Note: Two-Piece top option not available with surf edge profile. Also, Power Matrix (center of table location only) cannot be specified with this option.			
Power and Data Options		See pages 52-61	

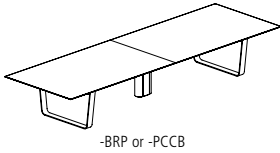
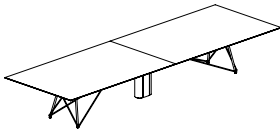
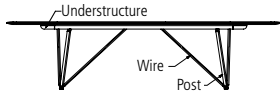

EDGE PROFILES

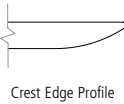
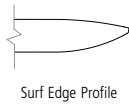

GENERAL INFORMATION

- Tops are 1-1/8" thick
- Seating capacity based on 27" per person
- Overall table height 29.5"
- Tables with three Hoop bases will default to three of the same base. If an alternate center base is needed, specify the -BRP or -PCCB Center Column Base option above.
- Wire Frame base tables 156" or longer include a center column in the same finish as the base. When the Wire Frame base is polished chrome, the center column base will default to Foil. When blackened nickel is specified, the center column base will default to Storm. When specified with the combination finish option, the center column base finish will need to be specified.
- Standard with flat cut veneer
- When Hoop Base or Wire Frame Base is specified in Polished Chrome, the support rails for the table will default to Black
- If selecting Blackened Nickel base finish, choose Storm for Wire Management color

REQUIRED INFORMATION (ORDER CANNOT BE ENTERED WITHOUT THIS INFORMATION)

- See appendix pages vi-vii for surface material options.
- Choose Metal Finish. Clear Anodized (-CA) not available



PLANK VENEER TOP



RECTANGLE TOP

EDGE PROFILE / BASE KEY

CREST EDGE PROFILE
 WF Wire Frame
 HP Hoop Base

RECTANGLE TABLES

MODEL #	L x W	TOP SECTIONS	BASE QTY	WIRE FRAME SEATING CAPACITY	HOOP BASE SEATING CAPACITY	-WF	-HP
BJT-7242-PW	72 x 42	1	2	6	4	11,146	9,425
BJT-7842-PW	78 x 42	1	2	6	4	12,234	10,393
BJT-8442-PW	84 x 42	1	2	8	6	12,548	10,707
BJT-8448-PW	84 x 48	1	2	8	8	13,549	11,643
BJT-9042-PW	90 x 42	1	2	8	6	13,530	11,594
BJT-9048-PW	90 x 48	1	2	8	8	14,637	12,632
BJT-9642-PW	96 x 42	1	2	8	8	13,861	11,925
BJT-9648-PW	96 x 48	1	2	8	8	15,021	13,017
BJT-10242-PW	102 x 42	1	2	8	8	14,980	12,936
BJT-10248-PW	102 x 48	1	2	8	8	16,261	14,147
BJT-10842-PW	108 x 42	1	2	10	8	15,330	13,285
BJT-10848-PW	108 x 48	1	2	10	8	16,667	14,553
BJT-11442-PW	114 x 42	1	2	10	8	16,504	14,351
BJT-11448-PW	114 x 48	1	2	10	10	17,973	15,746
BJT-12042-PW	120 x 42	1	2	10	10	16,872	14,719
BJT-12048-PW	120 x 48	1	2	10	10	18,399	16,173
BJT-12054-PW	120 x 54	1	2	12	10	20,205	17,880
BJT-13248-PW	132 x 48	2	2	10	10	20,056	17,738
BJT-13254-PW	132 x 54	2	2	12	10	22,080	19,659
BJT-14448-PW	144 x 48	2	2	12	12	21,785	19,373
BJT-14454-PW	144 x 54	2	2	14	12	24,038	21,518
BJT-14460-PW	144 x 60	2	2	14	12	26,670	24,017
BJT-15654-PW	156 x 54	2	3	14	10	30,878	27,060
BJT-15660-PW	156 x 60	2	3	14	10	34,001	29,981
BJT-16854-PW	168 x 54	2	3	16	10	32,075	28,258
BJT-16860-PW	168 x 60	2	3	16	10	35,376	31,355
BJT-18054-PW	180 x 54	2	3	16	14	33,272	29,454
BJT-18060-PW	180 x 60	2	3	16	14	36,751	32,731
BJT-19254-PW	192 x 54	2	3	18	14	34,469	30,653
BJT-19260-PW	192 x 60	2	3	18	14	38,125	34,105
BJT-20454-PW	204 x 54	2	3	18	14	37,114	33,142
BJT-20460-PW	204 x 60	2	3	18	14	41,104	36,920
BJT-21654-PW	216 x 54	2	3	20	14	39,296	35,227
BJT-21660-PW	216 x 60	2	3	20	14	43,572	39,286
BJT-22854-PW	228 x 54	2	3	20	18	40,959	36,851
BJT-22860-PW	228 x 60	2	3	20	18	45,467	41,141
BJT-24054-PW	240 x 54	2	3	20	18	42,725	38,570
BJT-24060-PW	240 x 60	2	3	20	18	47,478	43,102



PLANK VENEER TOP

OPTIONS	CODE	PRICE	NOTES
Polished Chrome Base Finish Options:			
(2) Hoop Bases	-PCH2	\$4,675	
(3) Hoop Bases	-PCH3	\$7,012	
Wire Frame Base 72"-132"	-PCWFR-1	\$2,924	
Wire Frame Base 144"-240"	-PCWFR-2	\$4,869	
Blackened Nickel Base Finish Options:			
(2) Hoop Bases	-BNH2	\$4,675	
(3) Hoop Bases	-BNH3	\$7,012	
Wire Frame Base 72"-132"	-BNWFR-1	\$2,924	
Wire Frame Base 144"-240"	-BNWFR-2	\$4,869	
Wire Frame Combination Finish Options:			
Polished Chrome Wires with Blackened Nickel Posts	-TTR-BN	\$3,033	
Polished Chrome Wires with Satin Chrome Posts	-TTR-BC	\$3,174	
Polished Chrome Wires with Powder Coat Posts	-TTR-P	\$2,804	
Center Column Finish Options:			
Polished Chrome Center Column Base	-PCCB	\$1,561	
Powder Coat Center Column Base*	-BRP	No Charge	Replaces existing middle base on Hoop Base
*When specifying -BRP in conjunction with a Polished Chrome finish on Hoop Base tables with 3 bases, use the upcharge code and pricing for 2 base tables (-PCH2)			
Multi-Section Tops:			
102", 108", 114" and 120" one-piece tops split into two sections	Specify -2**	\$1,006	
204", 216", 228" or 240" two-piece tops split into four sections	Specify -4	\$2,010	
**Note: Two-Piece top option not available with surf edge profile. Also, Power Matrix (center of table location only) cannot be specified with this option.			
Power and Data Options	See pages 52-61		

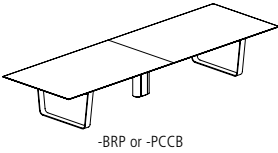
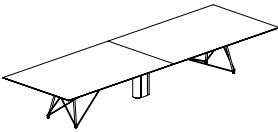
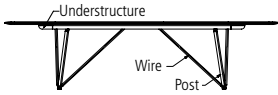

EDGE PROFILE

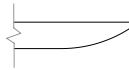

Crest Edge Profile

GENERAL INFORMATION

- Tops are 1-1/8" thick
- Seating capacity based on 27" per person
- Overall table height 29.5"
- Tables with three Hoop bases will default to three of the same base. If an alternate center base is needed, specify the -BRP or -PCCB Center Column Base option above.
- Wire Frame base tables 156" or longer include a center column in the same finish as the base. When the Wire Frame base is polished chrome, the center column base will default to Foil. When blackened nickel is specified, the center column base will default to Storm. When specified with the combination finish option, the center column base finish will need to be specified.
- Standard with flat cut veneer
- When Hoop Base or Wire Frame Base is specified in Polished Chrome, the support rails for the table will default to Black
- If selecting Blackened Nickel base finish, choose Storm for Wire Management color

REQUIRED INFORMATION (ORDER CANNOT BE ENTERED WITHOUT THIS INFORMATION)

See appendix pages vi-vii for surface material options.

- Choose Metal Finish



LAMINATE TOP WITH SQUARE EDGE

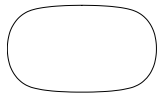

SOFT RECTANGLE TOP

EDGE PROFILE / BASE KEY

CREST EDGE PROFILE
 WF Wire Frame
 HP Hoop Base

SOFT RECTANGLE TABLES

MODEL #	L x W	TOP SECTIONS	BASE QTY	WIRE FRAME SEATING CAPACITY	HOOP BASE SEATING CAPACITY	-WF	-HP
BJF-7242-PA	72 x 42	1	2	6	4	8,723	7,376
BJF-7842-PA	78 x 42	1	2	6	4	9,575	8,134
BJF-8442-PA	84 x 42	1	2	8	6	9,820	8,379
BJF-8448-PA	84 x 48	1	2	8	8	10,603	9,112
BJF-9042-PA	90 x 42	1	2	8	6	10,589	9,073
BJF-9048-PA	90 x 48	1	2	8	8	11,455	9,886
BJF-9642-PA	96 x 42	1	2	8	8	10,848	9,333
BJF-9648-PA	96 x 48	1	2	8	8	11,755	10,188
BJF-10242-PA	102 x 42	1	2	8	8	11,724	10,124
BJF-10248-PA	102 x 48	1	2	8	8	12,726	11,071
BJF-10842-PA	108 x 42	1	2	10	8	11,997	10,397
BJF-10848-PA	108 x 48	1	2	10	8	13,044	11,389
BJF-11442-PA	114 x 42	1	2	10	8	12,916	11,232
BJF-11448-PA	114 x 48	1	2	10	10	14,066	12,323
BJF-12042-PA	120 x 42	1	2	10	10	13,204	11,520
BJF-12048-PA	120 x 48	1	2	10	10	14,400	12,657
BJF-12054-PA	120 x 54	1	2	12	10	15,813	13,993
BJF-13248-PA	132 x 48	2	2	10	10	15,696	13,882
BJF-13254-PA	132 x 54	2	2	12	10	17,280	15,385
BJF-14448-PA	144 x 48	2	2	12	12	17,049	15,162
BJF-14454-PA	144 x 54	2	2	14	12	18,812	16,840
BJF-14460-PA	144 x 60	2	2	14	12	20,872	18,796
BJF-15654-PA	156 x 54	2	3	14	10	24,165	21,177
BJF-15660-PA	156 x 60	2	3	14	10	26,610	23,463
BJF-16854-PA	168 x 54	2	3	16	10	25,102	22,115
BJF-16860-PA	168 x 60	2	3	16	10	27,685	24,539
BJF-18054-PA	180 x 54	2	3	16	14	26,039	23,051
BJF-18060-PA	180 x 60	2	3	16	14	28,762	25,615
BJF-19254-PA	192 x 54	2	3	18	14	26,976	23,989
BJF-19260-PA	192 x 60	2	3	18	14	29,837	26,691
BJF-20454-PA	204 x 54	2	3	18	14	29,046	25,938
BJF-20460-PA	204 x 60	2	3	18	14	32,168	28,894
BJF-21654-PA	216 x 54	2	3	20	14	30,753	27,569
BJF-21660-PA	216 x 60	2	3	20	14	34,100	30,745
BJF-22854-PA	228 x 54	2	3	20	18	32,055	28,840
BJF-22860-PA	228 x 60	2	3	20	18	35,583	32,197
BJF-24054-PA	240 x 54	2	3	20	18	33,437	30,186
BJF-24060-PA	240 x 60	2	3	20	18	37,157	33,732



LAMINATE TOP WITH SQUARE EDGE

OPTIONS	CODE	PRICE	NOTES
Polished Chrome Base Finish Options:			
(2) Hoop Bases	-PCH2	\$4,675	
(3) Hoop Bases	-PCH3	\$7,012	
Wire Frame Base 72"-132"	-PCWFR-1	\$2,924	
Wire Frame Base 144"-240"	-PCWFR-2	\$4,869	
Blackened Nickel Base Finish Options:			
(2) Hoop Bases	-BNH2	\$4,675	
(3) Hoop Bases	-BNH3	\$7,012	
Wire Frame Base 72"-132"	-BNWFR-1	\$2,924	
Wire Frame Base 144"-240"	-BNWFR-2	\$4,869	
Wire Frame Combination Finish Options:			
Polished Chrome Wires with Blackened Nickel Posts	-TTR-BN	\$3,033	
Polished Chrome Wires with Satin Chrome Posts	-TTR-BC	\$3,174	
Polished Chrome Wires with Powder Coat Posts	-TTR-P	\$2,804	
Center Column Finish Options:			
Polished Chrome Center Column Base	-PCCB	\$1,561	
Powder Coat Center Column Base*	-BRP	No Charge	Replaces existing middle base on Hoop Base
*When specifying -BRP in conjunction with a Polished Chrome finish on Hoop Base tables with 3 bases, use the upcharge code and pricing for 2 base tables (-PCH2)			
Multi-Section Tops:			
102", 108", 114" and 120" one-piece tops split into two sections	Specify -2**	\$1,006	
204", 216", 228" or 240" two-piece tops split into four sections	Specify -4	\$2,010	
**Note: Two-Piece top option not available with surf edge profile. Also, Power Matrix (center of table location only) cannot be specified with this option.			
Power and Data Options	See pages 52-61		

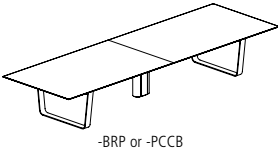
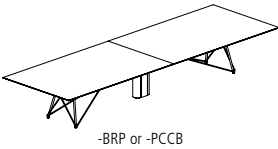
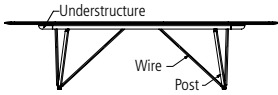

EDGE PROFILE

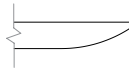

Crest Edge Profile

GENERAL INFORMATION

- Tops are 1-1/8" thick
- Seating capacity based on 27" per person
- Overall table height 29.5"
- Tables with three Hoop bases will default to three of the same base. If an alternate center base is needed, specify the -BRP or -PCCB Center Column Base option above.
- Wire Frame base tables 156" or longer include a center column in the same finish as the base. When the Wire Frame base is polished chrome, the center column base will default to Foil. When blackened nickel is specified, the center column base will default to Storm. When specified with the combination finish option, the center column base finish will need to be specified.
- When Hoop Base or Wire Frame Base is specified in Polished Chrome, the support rails for the table will default to Black
- If selecting Blackened Nickel base finish, choose Storm for Wire Management color

REQUIRED INFORMATION (ORDER CANNOT BE ENTERED WITHOUT THIS INFORMATION)

See appendix pages vi-vii for surface material options.

- Choose Laminate
- Choose Edge Band Finish
- Choose Metal Finish. Clear Anodized (-CA) not available.



LAMINATE TOP WITH SQUARE EDGE



RECTANGLE TOP

EDGE PROFILE / BASE KEY

CREST EDGE PROFILE
 WF Wire Frame
 HP Hoop Base

RECTANGLE TABLES

MODEL #	L x W	TOP SECTIONS	BASE QTY	WIRE FRAME SEATING CAPACITY	HOOP BASE SEATING CAPACITY	-WF	-HP
BJT-7242-PA	72 x 42	1	2	6	4	8,723	7,376
BJT-7842-PA	78 x 42	1	2	6	4	9,575	8,134
BJT-8442-PA	84 x 42	1	2	8	6	9,820	8,379
BJT-8448-PA	84 x 48	1	2	8	8	10,603	9,112
BJT-9042-PA	90 x 42	1	2	8	6	10,589	9,073
BJT-9048-PA	90 x 48	1	2	8	8	11,455	9,886
BJT-9642-PA	96 x 42	1	2	8	8	10,848	9,333
BJT-9648-PA	96 x 48	1	2	8	8	11,755	10,188
BJT-10242-PA	102 x 42	1	2	8	8	11,724	10,124
BJT-10248-PA	102 x 48	1	2	8	8	12,726	11,071
BJT-10842-PA	108 x 42	1	2	10	8	11,997	10,397
BJT-10848-PA	108 x 48	1	2	10	8	13,044	11,389
BJT-11442-PA	114 x 42	1	2	10	8	12,916	11,232
BJT-11448-PA	114 x 48	1	2	10	10	14,066	12,323
BJT-12042-PA	120 x 42	1	2	10	10	13,204	11,520
BJT-12048-PA	120 x 48	1	2	10	10	14,400	12,657
BJT-12054-PA	120 x 54	1	2	12	10	15,813	13,993
BJT-13248-PA	132 x 48	2	2	10	10	15,696	13,882
BJT-13254-PA	132 x 54	2	2	12	10	17,280	15,385
BJT-14448-PA	144 x 48	2	2	12	12	17,049	15,162
BJT-14454-PA	144 x 54	2	2	14	12	18,812	16,840
BJT-14460-PA	144 x 60	2	2	14	12	20,872	18,796
BJT-15654-PA	156 x 54	2	3	14	10	24,165	21,177
BJT-15660-PA	156 x 60	2	3	14	10	26,610	23,463
BJT-16854-PA	168 x 54	2	3	16	10	25,102	22,115
BJT-16860-PA	168 x 60	2	3	16	10	27,685	24,539
BJT-18054-PA	180 x 54	2	3	16	14	26,039	23,051
BJT-18060-PA	180 x 60	2	3	16	14	28,762	25,615
BJT-19254-PA	192 x 54	2	3	18	14	26,976	23,989
BJT-19260-PA	192 x 60	2	3	18	14	29,837	26,691
BJT-20454-PA	204 x 54	2	3	18	14	29,046	25,938
BJT-20460-PA	204 x 60	2	3	18	14	32,168	28,894
BJT-21654-PA	216 x 54	2	3	20	14	30,753	27,569
BJT-21660-PA	216 x 60	2	3	20	14	34,100	30,745
BJT-22854-PA	228 x 54	2	3	20	18	32,055	28,840
BJT-22860-PA	228 x 60	2	3	20	18	35,583	32,197
BJT-24054-PA	240 x 54	2	3	20	18	33,437	30,186
BJT-24060-PA	240 x 60	2	3	20	18	37,157	33,732



LAMINATE TOP WITH SQUARE EDGE

OPTIONS	CODE	PRICE	NOTES
Polished Chrome Base Finish Options:			
(2) Hoop Bases	-PCH2	\$4,675	
(3) Hoop Bases	-PCH3	\$7,012	
Wire Frame Base 72"-132"	-PCWFR-1	\$2,924	
Wire Frame Base 144"-240"	-PCWFR-2	\$4,869	
Blackened Nickel Base Finish Options:			
(2) Hoop Bases	-BNH2	\$4,675	
(3) Hoop Bases	-BNH3	\$7,012	
Wire Frame Base 72"-132"	-BNWFR-1	\$2,924	
Wire Frame Base 144"-240"	-BNWFR-2	\$4,869	
Wire Frame Combination Finish Options:			
Polished Chrome Wires with Blackened Nickel Posts	-TTR-BN	\$3,033	
Polished Chrome Wires with Satin Chrome Posts	-TTR-BC	\$3,174	
Polished Chrome Wires with Powder Coat Posts	-TTR-P	\$2,804	
Center Column Finish Options:			
Polished Chrome Center Column Base	-PCCB	\$1,561	
Powder Coat Center Column Base*	-BRP	No Charge	Replaces existing middle base on Hoop Base
*When specifying -BRP in conjunction with a Polished Chrome finish on Hoop Base tables with 3 bases, use the upcharge code and pricing for 2 base tables (-PCH2)			
Multi-Section Tops:			
102", 108", 114" and 120" one-piece tops split into two sections	Specify -2**	\$1,006	
204", 216", 228" or 240" two-piece tops split into four sections	Specify -4	\$2,010	
**Note: Two-Piece top option not available with surf edge profile. Also, Power Matrix (center of table location only) cannot be specified with this option.			
Power and Data Options	See pages 52-61		

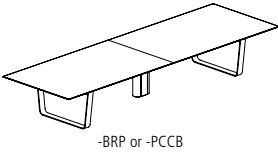
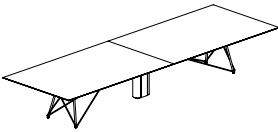
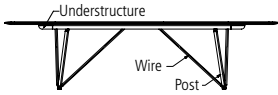

EDGE PROFILE

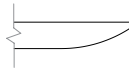

Crest Edge Profile

GENERAL INFORMATION

- Tops are 1-1/8" thick
- Seating capacity based on 27" per person
- Overall table height 29.5"
- Tables with three Hoop bases will default to three of the same base. If an alternate center base is needed, specify the -BRP or -PCCB Center Column Base option above.
- Wire Frame base tables 156" or longer include a center column in the same finish as the base. When the Wire Frame base is polished chrome, the center column base will default to Foil. When blackened nickel is specified, the center column base will default to Storm. When specified with the combination finish option, the center column base finish will need to be specified.
- When Hoop Base or Wire Frame Base is specified in Polished Chrome, the support rails for the table will default to Black
- If selecting Blackened Nickel base finish, choose Storm for Wire Management color

REQUIRED INFORMATION (ORDER CANNOT BE ENTERED WITHOUT THIS INFORMATION)

See appendix pages vi-vii for surface material options.

- Choose Laminate
- Choose Edge Band Finish
- Choose Metal Finish



INSET LAMINATE TOP WITH HARDWOOD EDGE

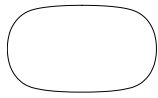

SOFT RECTANGLE TOP

EDGE PROFILE / BASE KEY

CREST EDGE PROFILE
 WF Wire Frame
 HP Hoop Base

SOFT RECTANGLE TABLES

MODEL #	L x W	TOP SECTIONS	BASE QTY	WIRE FRAME SEATING CAPACITY	HOOP BASE SEATING CAPACITY	-WF	-HP
BJF-7242-P	72 x 42	1	2	6	4	8,723	7,376
BJF-7842-P	78 x 42	1	2	6	4	9,575	8,134
BJF-8442-P	84 x 42	1	2	8	6	9,820	8,379
BJF-8448-P	84 x 48	1	2	8	8	10,603	9,112
BJF-9042-P	90 x 42	1	2	8	6	10,589	9,073
BJF-9048-P	90 x 48	1	2	8	8	11,455	9,886
BJF-9642-P	96 x 42	1	2	8	8	10,848	9,333
BJF-9648-P	96 x 48	1	2	8	8	11,755	10,188
BJF-10242-P	102 x 42	1	2	8	8	11,724	10,124
BJF-10248-P	102 x 48	1	2	8	8	12,726	11,071
BJF-10842-P	108 x 42	1	2	10	8	11,997	10,397
BJF-10848-P	108 x 48	1	2	10	8	13,044	11,389
BJF-11442-P	114 x 42	1	2	10	8	12,916	11,232
BJF-11448-P	114 x 48	1	2	10	10	14,066	12,323
BJF-12042-P	120 x 42	1	2	10	10	13,204	11,520
BJF-12048-P	120 x 48	1	2	10	10	14,400	12,657
BJF-12054-P	120 x 54	1	2	12	10	15,813	13,993
BJF-13248-P	132 x 48	2	2	10	10	15,696	13,882
BJF-13254-P	132 x 54	2	2	12	10	17,280	15,385
BJF-14448-P	144 x 48	2	2	12	12	17,049	15,162
BJF-14454-P	144 x 54	2	2	14	12	18,812	16,840
BJF-14460-P	144 x 60	2	2	14	12	20,872	18,796
BJF-15654-P	156 x 54	2	3	14	10	24,165	21,177
BJF-15660-P	156 x 60	2	3	14	10	26,610	23,463
BJF-16854-P	168 x 54	2	3	16	10	25,102	22,115
BJF-16860-P	168 x 60	2	3	16	10	27,685	24,539
BJF-18054-P	180 x 54	2	3	16	14	26,039	23,051
BJF-18060-P	180 x 60	2	3	16	14	28,762	25,615
BJF-19254-P	192 x 54	2	3	18	14	26,976	23,989
BJF-19260-P	192 x 60	2	3	18	14	29,837	26,691
BJF-20454-P	204 x 54	2	3	18	14	29,046	25,938
BJF-20460-P	204 x 60	2	3	18	14	32,168	28,894
BJF-21654-P	216 x 54	2	3	20	14	30,753	27,569
BJF-21660-P	216 x 60	2	3	20	14	34,100	30,745
BJF-22854-P	228 x 54	2	3	20	18	32,055	28,840
BJF-22860-P	228 x 60	2	3	20	18	35,583	32,197
BJF-24054-P	240 x 54	2	3	20	18	33,437	30,186
BJF-24060-P	240 x 60	2	3	20	18	37,157	33,732



INSET LAMINATE TOP WITH HARDWOOD EDGE

OPTIONS	CODE	PRICE	NOTES
Polished Chrome Base Finish Options:			
(2) Hoop Bases	-PCH2	\$4,675	
(3) Hoop Bases	-PCH3	\$7,012	
Wire Frame Base 72"-132"	-PCWFR-1	\$2,924	
Wire Frame Base 144"-240"	-PCWFR-2	\$4,869	
Blackened Nickel Base Finish Options:			
(2) Hoop Bases	-BNH2	\$4,675	
(3) Hoop Bases	-BNH3	\$7,012	
Wire Frame Base 72"-132"	-BNWFR-1	\$2,924	
Wire Frame Base 144"-240"	-BNWFR-2	\$4,869	
Wire Frame Combination Finish Options:			
Polished Chrome Wires with Blackened Nickel Posts	-TTR-BN	\$3,033	
Polished Chrome Wires with Satin Chrome Posts	-TTR-BC	\$3,174	
Polished Chrome Wires with Powder Coat Posts	-TTR-P	\$2,804	
Center Column Finish Options:			
Polished Chrome Center Column Base	-PCCB	\$1,561	
Powder Coat Center Column Base*	-BRP	No Charge	Replaces existing middle base on Hoop Base
*When specifying -BRP in conjunction with a Polished Chrome finish on Hoop Base tables with 3 bases, use the upcharge code and pricing for 2 base tables (-PCH2)			
Multi-Section Tops:			
102", 108", 114" and 120" one-piece tops split into two sections	Specify -2**	\$1,006	
204", 216", 228" or 240" two-piece tops split into four sections	Specify -4	\$2,010	
**Note: Two-Piece top option not available with surf edge profile. Also, Power Matrix (center of table location only) cannot be specified with this option.			
Power and Data Options	See pages 52-61		

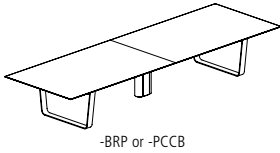
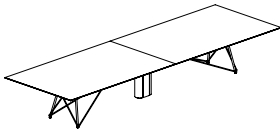
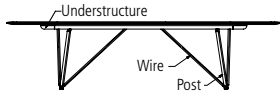

EDGE PROFILE

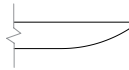

Crest Edge Profile

GENERAL INFORMATION

- Tops are 1-1/8" thick
- Seating capacity based on 27" per person
- Overall table height 29.5"
- Tables with three Hoop bases will default to three of the same base. If an alternate center base is needed, specify the -BRP or -PCCB Center Column Base option above.
- Wire Frame base tables 156" or longer include a center column in the same finish as the base. When the Wire Frame base is polished chrome, the center column base will default to Foil. When blackened nickel is specified, the center column base will default to Storm. When specified with the combination finish option, the center column base finish will need to be specified.
- When Hoop Base or Wire Frame Base is specified in Polished Chrome, the support rails for the table will default to Black
- If selecting Blackened Nickel base finish, choose Storm for Wire Management color

REQUIRED INFORMATION (ORDER CANNOT BE ENTERED WITHOUT THIS INFORMATION)

See appendix pages vi-vii for surface material options.

- Choose Laminate
- Choose Veneer
- Choose Metal Finish. Clear Anodized (-CA) not available.



INSET LAMINATE TOP WITH HARDWOOD EDGE



RECTANGLE TOP

EDGE PROFILE / BASE KEY

CREST EDGE PROFILE
 WF Wire Frame
 HP Hoop Base

RECTANGLE TABLES

MODEL #	L x W	TOP SECTIONS	BASE QTY	WIRE FRAME SEATING CAPACITY	HOOP BASE SEATING CAPACITY	-WF	-HP
BJT-7242-P	72 x 42	1	2	6	4	8,723	7,376
BJT-7842-P	78 x 42	1	2	6	4	9,575	8,134
BJT-8442-P	84 x 42	1	2	8	6	9,820	8,379
BJT-8448-P	84 x 48	1	2	8	8	10,603	9,112
BJT-9042-P	90 x 42	1	2	8	6	10,589	9,073
BJT-9048-P	90 x 48	1	2	8	8	11,455	9,886
BJT-9642-P	96 x 42	1	2	8	8	10,848	9,333
BJT-9648-P	96 x 48	1	2	8	8	11,755	10,188
BJT-10242-P	102 x 42	1	2	8	8	11,724	10,124
BJT-10248-P	102 x 48	1	2	8	8	12,726	11,071
BJT-10842-P	108 x 42	1	2	10	8	11,997	10,397
BJT-10848-P	108 x 48	1	2	10	8	13,044	11,389
BJT-11442-P	114 x 42	1	2	10	8	12,916	11,232
BJT-11448-P	114 x 48	1	2	10	10	14,066	12,323
BJT-12042-P	120 x 42	1	2	10	10	13,204	11,520
BJT-12048-P	120 x 48	1	2	10	10	14,400	12,657
BJT-12054-P	120 x 54	1	2	12	10	15,813	13,993
BJT-13248-P	132 x 48	2	2	10	10	15,696	13,882
BJT-13254-P	132 x 54	2	2	12	10	17,280	15,385
BJT-14448-P	144 x 48	2	2	12	12	17,049	15,162
BJT-14454-P	144 x 54	2	2	14	12	18,812	16,840
BJT-14460-P	144 x 60	2	2	14	12	20,872	18,796
BJT-15654-P	156 x 54	2	3	14	10	24,165	21,177
BJT-15660-P	156 x 60	2	3	14	10	26,610	23,463
BJT-16854-P	168 x 54	2	3	16	10	25,102	22,115
BJT-16860-P	168 x 60	2	3	16	10	27,685	24,539
BJT-18054-P	180 x 54	2	3	16	14	26,039	23,051
BJT-18060-P	180 x 60	2	3	16	14	28,762	25,615
BJT-19254-P	192 x 54	2	3	18	14	26,976	23,989
BJT-19260-P	192 x 60	2	3	18	14	29,837	26,691
BJT-20454-P	204 x 54	2	3	18	14	29,046	25,938
BJT-20460-P	204 x 60	2	3	18	14	32,168	28,894
BJT-21654-P	216 x 54	2	3	20	14	30,753	27,569
BJT-21660-P	216 x 60	2	3	20	14	34,100	30,745
BJT-22854-P	228 x 54	2	3	20	18	32,055	28,840
BJT-22860-P	228 x 60	2	3	20	18	35,583	32,197
BJT-24054-P	240 x 54	2	3	20	18	33,437	30,186
BJT-24060-P	240 x 60	2	3	20	18	37,157	33,732



INSET LAMINATE TOP WITH HARDWOOD EDGE

OPTIONS	CODE	PRICE	NOTES
Polished Chrome Base Finish Options:			
(2) Hoop Bases	-PCH2	\$4,675	
(3) Hoop Bases	-PCH3	\$7,012	
Wire Frame Base 72"-132"	-PCWFR-1	\$2,924	
Wire Frame Base 144"-240"	-PCWFR-2	\$4,869	
Blackened Nickel Base Finish Options:			
(2) Hoop Bases	-BNH2	\$4,675	
(3) Hoop Bases	-BNH3	\$7,012	
Wire Frame Base 72"-132"	-BNWFR-1	\$2,924	
Wire Frame Base 144"-240"	-BNWFR-2	\$4,869	
Wire Frame Combination Finish Options:			
Polished Chrome Wires with Blackened Nickel Posts	-TTR-BN	\$3,033	
Polished Chrome Wires with Satin Chrome Posts	-TTR-BC	\$3,174	
Polished Chrome Wires with Powder Coat Posts	-TTR-P	\$2,804	
Center Column Finish Options:			
Polished Chrome Center Column Base	-PCCB	\$1,561	
Powder Coat Center Column Base*	-BRP	No Charge	Replaces existing middle base on Hoop Base
*When specifying -BRP in conjunction with a Polished Chrome finish on Hoop Base tables with 3 bases, use the upcharge code and pricing for 2 base tables (-PCH2)			
Multi-Section Tops:			
102", 108", 114" and 120" one-piece tops split into two sections	Specify -2**	\$1,006	
204", 216", 228" or 240" two-piece tops split into four sections	Specify -4	\$2,010	
**Note: Two-Piece top option not available with surf edge profile. Also, Power Matrix (center of table location only) cannot be specified with this option.			
Power and Data Options	See pages 52-61		

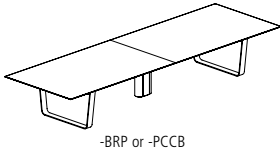
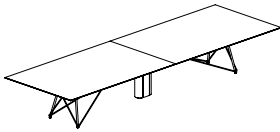
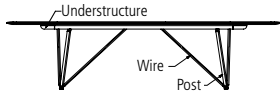

EDGE PROFILE

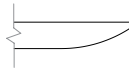

Crest Edge Profile

GENERAL INFORMATION

- Tops are 1-1/8" thick
- Seating capacity based on 27" per person
- Overall table height 29.5"
- Tables with three Hoop bases will default to three of the same base. If an alternate center base is needed, specify the -BRP or -PCCB Center Column Base option above.
- Wire Frame base tables 156" or longer include a center column in the same finish as the base. When the Wire Frame base is polished chrome, the center column base will default to Foil. When blackened nickel is specified, the center column base will default to Storm. When specified with the combination finish option, the center column base finish will need to be specified.
- When Hoop Base or Wire Frame Base is specified in Polished Chrome, the support rails for the table will default to Black
- If selecting Blackened Nickel base finish, choose Storm for Wire Management color

REQUIRED INFORMATION (ORDER CANNOT BE ENTERED WITHOUT THIS INFORMATION)

See appendix pages vi-vii for surface material options.

- Choose Laminate
- Choose Edge Band Finish
- Choose Metal Finish



GLASS TOP

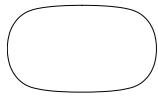

SOFT RECTANGLE TOP

EDGE PROFILE / BASE KEY

GLASS EDGE PROFILE
 WF Wire Frame
 HP Hoop Base

SOFT RECTANGLE TABLES

MODEL #	L x W	SUB-TOP SECTIONS	GLASS TOP SECTIONS	BASE QTY	WIRE FRAME SEATING CAPACITY	HOOP BASE SEATING CAPACITY	-WF	-HP
BJF-7242-G	72 x 42	1	1	2	6	4	12,741	11,244
BJF-7842-G	78 x 42	1	1	2	6	4	14,062	12,461
BJF-8442-G	84 x 42	1	1	2	8	6	14,498	12,897
BJF-8448-G	84 x 48	1	1	2	8	8	15,827	14,170
BJF-9042-G	90 x 42	1	1	2	8	6	15,709	14,025
BJF-9048-G	90 x 48	1	1	2	8	8	17,186	15,443
BJF-9642-G	96 x 42	1	1	2	8	8	16,168	14,484
BJF-9648-G	96 x 48	1	1	2	8	8	17,723	15,981
BJF-10242-G	102 x 42	1	2	2	8	8	17,551	15,773
BJF-10248-G	102 x 48	1	2	2	8	8	19,273	17,434
BJF-10842-G	108 x 42	1	2	2	10	8	18,035	16,257
BJF-10848-G	108 x 48	1	2	2	10	8	19,841	18,002
BJF-11442-G	114 x 42	1	2	2	10	8	19,494	17,622
BJF-11448-G	114 x 48	1	2	2	10	10	21,482	19,546
BJF-12042-G	120 x 42	1	2	2	10	10	20,003	18,131
BJF-12048-G	120 x 48	1	2	2	10	10	22,077	20,141
BJF-12054-G	120 x 54	1	2	2	12	10	24,505	22,483
BJF-13248-G	132 x 48	2	3	2	10	10	24,240	22,224
BJF-13254-G	132 x 54	2	3	2	12	10	26,974	24,868
BJF-14448-G	144 x 48	2	3	2	12	12	26,502	24,405
BJF-14454-G	144 x 54	2	3	2	14	12	29,560	27,369
BJF-14460-G	144 x 60	2	3	2	14	12	33,113	30,806
BJF-15654-G	156 x 54	2	3	3	14	10	36,174	32,854
BJF-15660-G	156 x 60	2	3	3	14	10	40,265	36,769
BJF-16854-G	168 x 54	2	3	3	16	10	37,793	34,474
BJF-16860-G	168 x 60	2	3	3	16	10	42,138	38,642
BJF-18054-G	180 x 54	2	3	3	16	14	39,413	36,093
BJF-18060-G	180 x 60	2	3	3	16	14	44,010	40,514
BJF-19254-G	192 x 54	2	4	3	18	14	41,031	37,712
BJF-19260-G	192 x 60	2	4	3	18	14	45,881	42,385
BJF-20454-G	204 x 54	2	4	3	18	14	44,382	40,928
BJF-20460-G	204 x 60	2	4	3	18	14	49,692	46,054
BJF-21654-G	216 x 54	2	4	3	20	14	47,190	43,652
BJF-21660-G	216 x 60	2	4	3	20	14	52,900	49,173
BJF-22854-G	228 x 54	2	4	3	20	18	49,382	45,810
BJF-22860-G	228 x 60	2	4	3	20	18	55,418	51,656
BJF-24054-G	240 x 54	2	4	3	20	18	51,704	48,091
BJF-24060-G	240 x 60	2	4	3	20	18	58,082	54,277



GLASS TOP

OPTIONS	CODE	PRICE	NOTES
Polished Chrome Base Finish Options:			
(2) Hoop Bases	-PCH2	\$4,675	
(3) Hoop Bases	-PCH3	\$7,012	
Wire Frame Base 72"-132"	-PCWFR-1	\$2,924	
Wire Frame Base 144"-240"	-PCWFR-2	\$4,869	
Blackened Nickel Base Finish Options:			
(2) Hoop Bases	-BNH2	\$4,675	
(3) Hoop Bases	-BNH3	\$7,012	
Wire Frame Base 72"-132"	-BNWFR-1	\$2,924	
Wire Frame Base 144"-240"	-BNWFR-2	\$4,869	
Wire Frame Combination Finish Options:			
Polished Chrome Wires with Blackened Nickel Posts	-TTR-BN	\$3,033	
Polished Chrome Wires with Satin Chrome Posts	-TTR-BC	\$3,174	
Polished Chrome Wires with Powder Coat Posts	-TTR-P	\$2,804	
Center Column Finish Options:			
Polished Chrome Center Column Base	-PCCB	\$1,561	
Powder Coat Center Column Base*	-BRP	No Charge	Replaces existing middle base on Hoop Base
*When specifying -BRP in conjunction with a Polished Chrome finish on Hoop Base tables with 3 bases, use the upcharge code and pricing for 2 base tables (-PCH2)			
Satin Glass Options:			
72"-96" Tables	Add -BSG	\$695	
102"-132" Tables	Add -BSG	\$925	
144"-180" Tables	Add -BSG	\$1,159	
Multi-Section Tops:			
102", 108", 114" and 120" one-piece tops split into two sections	Specify -2**	\$1,006	
204", 216", 228" or 240" two-piece tops split into four sections	Specify -4	\$2,010	
**Note: Two-Piece top option not available with surf edge profile. Also, Power Matrix (center of table location only) cannot be specified with this option.			

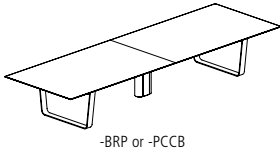
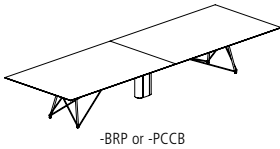
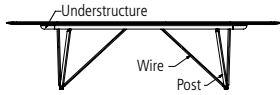

Power and Data Options See pages 52-61

EDGE PROFILE



Glass Edge Profile

GENERAL INFORMATION

- Tops are 1-1/8" thick
- Seating capacity based on 27" per person
- Overall table height 29.5"
- Tables with three Hoop bases will default to three of the same base. If an alternate center base is needed, specify the -BRP or -PCCB Center Column Base option above.
- Wire Frame base tables 156" or longer include a center column in the same finish as the base. When the Wire Frame base is polished chrome, the center column base will default to Foil. When blackened nickel is specified, the center column base will default to Storm. When specified with the combination finish option, the center column base finish will need to be specified.
- Unless otherwise specified, the sub-top finish will match the base finish, if Polished Chrome finish is specified for the base, the sub-top finish will be Foil
- When Hoop Base or Wire Frame Base is specified in Polished Chrome, the support rails for the table will default to Black
- If selecting Blackened Nickel base finish, choose Storm for Wire Management color

REQUIRED INFORMATION (ORDER CANNOT BE ENTERED WITHOUT THIS INFORMATION)

See appendix pages vi-vii for surface material options.

- Choose Glass Finish
- Choose Paint Sub-Top Finish
- Choose Metal Finish. Clear Anodized (-CA) not available.



GLASS TOP



RECTANGLE TOP

EDGE PROFILE / BASE KEY

GLASS EDGE PROFILE
 WF Wire Frame
 HP Hoop Base

RECTANGLE TABLES

MODEL #	L x W	SUB-TOP SECTIONS	GLASS TOP SECTIONS	BASE QTY	WIRE FRAME SEATING CAPACITY	HOOP BASE SEATING CAPACITY	-WF	-HP
BJT-7242-G	72 x 42	1	1	2	6	4	12,741	11,244
BJT-7842-G	78 x 42	1	1	2	6	4	14,062	12,461
BJT-8442-G	84 x 42	1	1	2	8	6	14,498	12,897
BJT-8448-G	84 x 48	1	1	2	8	8	15,827	14,170
BJT-9042-G	90 x 42	1	1	2	8	6	15,709	14,025
BJT-9048-G	90 x 48	1	1	2	8	8	17,186	15,443
BJT-9642-G	96 x 42	1	1	2	8	8	16,168	14,484
BJT-9648-G	96 x 48	1	1	2	8	8	17,723	15,981
BJT-10242-G	102 x 42	1	2	2	8	8	17,551	15,773
BJT-10248-G	102 x 48	1	2	2	8	8	19,273	17,434
BJT-10842-G	108 x 42	1	2	2	10	8	18,035	16,257
BJT-10848-G	108 x 48	1	2	2	10	8	19,841	18,002
BJT-11442-G	114 x 42	1	2	2	10	8	19,494	17,622
BJT-11448-G	114 x 48	1	2	2	10	10	21,482	19,546
BJT-12042-G	120 x 42	1	2	2	10	10	20,003	18,131
BJT-12048-G	120 x 48	1	2	2	10	10	22,077	20,141
BJT-12054-G	120 x 54	1	2	2	12	10	24,505	22,483
BJT-13248-G	132 x 48	2	3	2	10	10	24,240	22,224
BJT-13254-G	132 x 54	2	3	2	12	10	26,974	24,868
BJT-14448-G	144 x 48	2	3	2	12	12	26,502	24,405
BJT-14454-G	144 x 54	2	3	2	14	12	29,560	27,369
BJT-14460-G	144 x 60	2	3	2	14	12	33,113	30,806
BJT-15654-G	156 x 54	2	3	3	14	10	36,174	32,854
BJT-15660-G	156 x 60	2	3	3	14	10	40,265	36,769
BJT-16854-G	168 x 54	2	3	3	16	10	37,793	34,474
BJT-16860-G	168 x 60	2	3	3	16	10	42,138	38,642
BJT-18054-G	180 x 54	2	3	3	16	14	39,413	36,093
BJT-18060-G	180 x 60	2	3	3	16	14	44,010	40,514
BJT-19254-G	192 x 54	2	4	3	18	14	41,031	37,712
BJT-19260-G	192 x 60	2	4	3	18	14	45,881	42,385
BJT-20454-G	204 x 54	2	4	3	18	14	44,382	40,928
BJT-20460-G	204 x 60	2	4	3	18	14	49,692	46,054
BJT-21654-G	216 x 54	2	4	3	20	14	47,190	43,652
BJT-21660-G	216 x 60	2	4	3	20	14	52,900	49,173
BJT-22854-G	228 x 54	2	4	3	20	18	49,382	45,810
BJT-22860-G	228 x 60	2	4	3	20	18	55,418	51,656
BJT-24054-G	240 x 54	2	4	3	20	18	51,704	48,091
BJT-24060-G	240 x 60	2	4	3	20	18	58,082	54,277



GLASS TOP

OPTIONS	CODE	PRICE	NOTES
---------	------	-------	-------

Polished Chrome Base Finish Options:			
(2) Hoop Bases	-PCH2	\$4,675	
(3) Hoop Bases	-PCH3	\$7,012	
Wire Frame Base 72"-132"	-PCWFR-1	\$2,924	
Wire Frame Base 144"-240"	-PCWFR-2	\$4,869	

Blackened Nickel Base Finish Options:			
(2) Hoop Bases	-BNH2	\$4,675	
(3) Hoop Bases	-BNH3	\$7,012	
Wire Frame Base 72"-132"	-BNWFR-1	\$2,924	
Wire Frame Base 144"-240"	-BNWFR-2	\$4,869	

Wire Frame Combination Finish Options:			
Polished Chrome Wires with Blackened Nickel Posts	-TTR-BN	\$3,033	
Polished Chrome Wires with Satin Chrome Posts	-TTR-BC	\$3,174	
Polished Chrome Wires with Powder Coat Posts	-TTR-P	\$2,804	

Center Column Finish Options:			
Polished Chrome Center Column Base	-PCCB	\$1,561	
Powder Coat Center Column Base*	-BRP	No Charge	Replaces existing middle base on Hoop Base
*When specifying -BRP in conjunction with a Polished Chrome finish on Hoop Base tables with 3 bases, use the upcharge code and pricing for 2 base tables (-PCH2)			

Satin Glass Options:			
72"-96" Tables	Add -BSG	\$695	
102"-132" Tables	Add -BSG	\$925	
144"-180" Tables	Add -BSG	\$1,159	

Multi-Section Tops:			
102", 108", 114" and 120" one-piece tops split into two sections	Specify -2**	\$1,006	
204", 216", 228" or 240" two-piece tops split into four sections	Specify -4	\$2,010	
**Note: Two-Piece top option not available with surf edge profile. Also, Power Matrix (center of table location only) cannot be specified with this option.			

Power and Data Options See pages 52-61

EDGE PROFILE

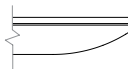

Glass Edge Profile

GENERAL INFORMATION

- Tops are 1-1/8" thick
- Seating capacity based on 27" per person
- Overall table height 29.5"
- Tables with three Hoop bases will default to three of the same base. If an alternate center base is needed, specify the -BRP or -PCCB Center Column Base option above.
- Wire Frame base tables 156" or longer include a center column in the same finish as the base. When the Wire Frame base is polished chrome, the center column base will default to Foil. When blackened nickel is specified, the center column base will default to Storm. When specified with the combination finish option, the center column base finish will need to be specified.
- Unless otherwise specified, the sub-top finish will match the base finish, if Polished Chrome finish is specified for the base, the sub-top finish will be Foil
- When Hoop Base or Wire Frame Base is specified in Polished Chrome, the support rails for the table will default to Black
- If selecting Blackened Nickel base finish, choose Storm for Wire Management color

REQUIRED INFORMATION (ORDER CANNOT BE ENTERED WITHOUT THIS INFORMATION)

See appendix pages vi-vii for surface material options.

- Choose Glass Finish
- Choose Paint Sub-Top Finish
- Choose Metal Finish. Clear Anodized (-CA) not available.

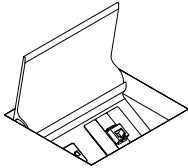

POWER AND DATA OPTIONS

POWER MATRIX SMALL	MODEL #	DESCRIPTION	W x D	SIMPLEX OUTLETS	BLANK	DATA*	PRICE
	PM-SM-G	Small - Glass Door	6 x 5.375	2	2	1	1,635
	PM-SM-M	Small - Metal Door	6 x 5.375	2	2	1	1,635
	PM-SM-W	Small - Wood Door	6 x 5.375	2	2	1	2,062

*Each data faceplate includes two RJ-45 (Data) connectors

OPTIONS	CODE	PRICE	NOTES
4 Simplex Receptacles	Add -FOUR	No Charge	Replace Modular AV Inserts/Plates with 2 simplex receptacles
3 Simplex Receptacles/Charging USB-A+C	Add -THREE-C	No Charge	Replace Modular AV Inserts/Plates with 1 simplex receptacle and 1 charging USB-A+C
USB-A+C Charging	Add -USB-C	\$128 per unit	USB-A+C charger, replaces one of the simplex outlets
Polished Chrome Door	Add -PD	\$245 per unit	Only available with metal door option
Polished Chrome Bezel	Add -PB	\$349 per unit	Only available on glass and laminate top tables
Field-Wired	Add -FW	Deduct \$48 per unit	May be required in New York City, Chicago and San Francisco. Check with an electrician for local codes and requirements.
Single Infeed Option Available	See page 60		

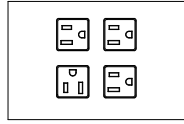

-FOUR

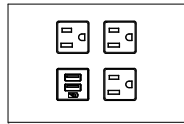

-THREE-C

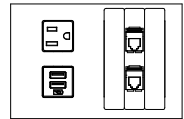

-USB-C

GENERAL INFORMATION

- Wood species and finish will default to the same as the table top if wood door version is specified
- Glass & wood doors are 1/4" -thick, metal doors are 1/8" -thick
- Glass door is back-painted low-iron glass
- Interior body is clear anodized aluminum
- Each unit includes a 15 amp, 12' power infeed (plug in only)
- If Field-Wired option is specified, each unit includes a 6' flexible metal conduit and requires a hardwire connection
- Standard configuration: Two simplex receptacles, two RJ-45 data connectors and two single blank faceplates
- When specified on tables with laminate or glass tops, each Power Matrix unit will include a metal bezel and is limited to the glass and metal door options. (-B) will be added to the model number for the bezel.
- Additional data/AV faceplate options are on page 60

REQUIRED INFORMATION: (ORDER CANNOT BE ENTERED WITHOUT THIS INFORMATION)

See appendix pages vi-vii for surface material options.

- Choose location code & quantity from the chart on page 54
- Choose Glass Door Finish, if glass door version is specified
- Choose Metal Finish, if metal door version is specified or for the bezel finish on laminate and glass tables

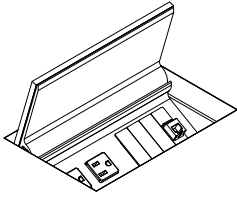

POWER AND DATA OPTIONS

POWER MATRIX MEDIUM	MODEL #	DESCRIPTION	W x D	SIMPLEX OUTLETS	BLANK	DATA*	PRICE
	PM-MD-G	Medium - Glass Door	6 x 8.25	4	3	1	2,576
	PM-MD-M	Medium - Metal Door	6 x 8.25	4	3	1	2,576
	PM-MD-W	Medium - Wood Door	6 x 8.25	4	3	1	3,006

*Each data faceplate includes two RJ-45 (Data) connectors

OPTIONS	CODE	PRICE	NOTES
USB-A+C Charging	Add -USB-C	\$128 per unit	USB-A+C charger, replaces one of the simplex outlets
Polished Chrome Door	Add -PD	\$330 per unit	Only available with metal door option
Polished Chrome Bezel	Add -PB	\$390 per unit	Only available on glass and laminate top tables
Field-Wired	Add -FW	Deduct \$48 per unit	May be required in New York City, Chicago and San Francisco. Check with an electrician for local codes and requirements.
Single Infeed Option Available	See page 60		

GENERAL INFORMATION

- Wood species and finish will default to the same as the table top if wood door version is specified
- Glass & wood doors are 1/4" -thick, metal doors are 1/8" -thick
- Glass door is back-painted low-iron glass
- Interior body is clear anodized aluminum
- Each unit includes a 15 amp, 12' power infeed (plug in only)
- If Field-Wired option is specified, each unit includes a 6' flexible metal conduit and requires a hardwire connection
- Standard configuration: Four simplex receptacles, two RJ-45 data connectors and three single blank faceplates
- When specified on tables with laminate, glass or stone/quartz tops, each Power Matrix unit will include a metal bezel and is limited to the glass and metal door options. (-B) will be added to the model number for the bezel.
- Additional data/AV faceplate options are on page 60

REQUIRED INFORMATION: (ORDER CANNOT BE ENTERED WITHOUT THIS INFORMATION)

See appendix pages vi-vii for surface material options.

- Choose location code & quantity from the chart on page 54
- Choose Glass Door Finish, if glass door version is specified
- Choose Metal Finish, if metal door version is specified or for the bezel finish on laminate and glass tables



POWER AND DATA OPTIONS

LOCATION CODES	POWER MATRIX SMALL	POWER MATRIX MEDIUM	LOCATION	QUANTITY OF UNITS TO ORDER
PS-1		PM-1	One at center	1
PS-2		PM-2	One at each end	2
PS-3		PM-3	One at center and one at each end	3
PS-4		PM-4	Four equally spaced	4

DOOR MATERIAL AND LOCATION AVAILABILITY BY TABLE SIZE

W = Wood Door G = Glass Door M = Metal Door

Length	Veneer & Laminate		Glass Top Sections	Power Matrix Small				Power Matrix Medium			
	Top Sections	Top Sections		1	1	PS-3	PS-4	PM-1	PM-2	PM-3	PM-4
42	1	1	1	W/G/M	-	-	-	W/G/M	-	-	-
48	1	1	1	W/G/M	-	-	-	W/G/M	-	-	-
54	1	1	1	W/G/M	-	-	-	W/G/M	-	-	-
60	1	1	1	W/G/M	-	-	-	W/G/M	-	-	-
72	1	1	1	W/G/M	W/G/M	-	-	W/G/M	W/G/M	-	-
78	1	1	1	W/G/M	W/G/M	-	-	W/G/M	W/G/M	-	-
84	1	1	1	W/G/M	W/G/M	-	-	W/G/M	W/G/M	-	-
90	1	1	1	W/G/M	W/G/M	-	-	W/G/M	W/G/M	-	-
96	1	1	1	W/G/M	W/G/M	W/G/M	-	W/G/M	W/G/M	W/G/M	-
102	1	2	2	W/G/M	W/G/M	W/G/M	-	W/G/M	W/G/M	W/G/M	-
102	2	2	2	-	W/G/M	-	-	-	W/G/M	-	-
108	1	2	2	W/G/M	W/G/M	W/G/M	-	W/G/M	W/G/M	W/G/M	-
108	2	2	2	-	W/G/M	-	-	-	W/G/M	-	-
114	1	2	2	W/G/M	W/G/M	W/G/M	-	W/G/M	W/G/M	W/G/M	-
114	2	2	2	-	W/G/M	-	-	-	W/G/M	-	-
120	1	2	2	W/G/M	W/G/M	W/G/M	-	W/G/M	W/G/M	W/G/M	-
120	2	2	2	-	W/G/M	-	-	-	W/G/M	-	-
132	2	3	3	-	W/G/M	-	W/G/M	-	W/G/M	-	W/G/M
144	2	3	3	-	W/G/M	-	W/G/M	-	W/G/M	-	W/G/M
156	2	3	3	-	W/G/M	-	W/G/M	-	W/G/M	-	W/G/M
168	2	3	3	-	W/G/M	-	W/G/M	-	W/G/M	-	W/G/M
180	2	3	3	-	W/G/M	-	W/G/M	-	W/G/M	-	W/G/M
192	2	4	4	-	W/G/M	-	W/G/M	-	W/G/M	-	W/G/M
192	4	4	4	-	W/G/M	-	W/G/M	-	W/G/M	-	W/G/M
204	2	4	4	-	W/G/M	-	W/G/M	-	W/G/M	-	W/G/M
204	4	4	4	-	W/G/M	-	W/G/M	-	W/G/M	-	W/G/M
216	2	4	4	-	W/G/M	-	W/G/M	-	W/G/M	-	W/G/M
216	4	4	4	-	W/G/M	-	W/G/M	-	W/G/M	-	W/G/M
228	2	4	4	-	W/G/M	-	W/G/M	-	W/G/M	-	W/G/M
228	4	4	4	-	W/G/M	-	W/G/M	-	W/G/M	-	W/G/M
240	2	4	4	-	W/G/M	-	W/G/M	-	W/G/M	-	W/G/M
240	4	4	4	-	W/G/M	-	W/G/M	-	W/G/M	-	W/G/M



POWER AND DATA OPTIONS

SINGLE INFEED OPTION	MODEL #	DESCRIPTION	PRICE
	SI-H	Single In-Feed Option, Hard-wired	608
	SI-C	Single In-Feed Option, Corded (Plug-in)	734

GENERAL INFORMATION

- Tables 48" -96" in length include 2 duplex receptacles with the modular power system
- Hardwired and Corded Single Infeed options are 7' long
- Single Infeed option cannot be specified in conjunction with the Field-Wired (-FW) option

RETRACTORS	MODEL #	DESCRIPTION	PRICE
	CR-CAT6	CAT6 Retractor	996
	CR-HDMI	HDMI Retractor	996
	CR-DISPLAY	Display Port Retractor	996
	CR-USB	Data USB Retractor	996

CR-HDMI

GENERAL INFORMATION

- Mounting bracket and attaching hardware included with each retractor
- Not available on square, round or soft square tables
- One Cable Pass Through Set (one top, one bottom) Modular AV Insert/Plate included. Double style Modular AV Inserts/Plates.

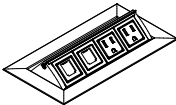

POWER AND DATA OPTIONS

TECH NODE	MODEL #	W X D	SIMPLEX RECEPTACLES	OPEN DATA PORTS	CHARGING USB-A+C	PRICE
 PUP	PUP	8 x 4	2	2	-	597
	PUP-USB-AC	8 x 4	2	1	1	711



OPTIONS	CODE	PRICE	NOTES
Field-Wired	Add -FW	No Charge	May be required in New York City, Chicago and San Francisco. Check with an electrician for local codes and requirements.

GENERAL INFORMATION

- 12' cord and a 15 amp plug-in power infeed
- Voice/data modules must be ordered separately; contact your local AV integrator
- PUP defaults to color of metal finish specified on tables (Shadow, Storm, Black, Aged Bronze, Satin Bronze and Galaxy receive Black Anodized Tech Node; Cloud, Burnished and Foil receive Clear Anodized Tech Node)
- Includes a Voice/Data Adapter Kit to accept couplers and jacks when required
- UL Listed

REQUIRED INFORMATION: (ORDER CANNOT BE ENTERED WITHOUT THIS INFORMATION)

- See appendix pages vi-vii for surface material options.
- Choose location code and quantity from chart on page 57



POWER SPEC	MODEL #	DESCRIPTION	PRICE
 PWR-R-W	PWR-R-B	Round Power Spec with Black Faceplate	128
	PWR-R-W	Round Power Spec with White Faceplate	128
 PWR-SQ-W	PWR-SQ-B	Square Power Spec with Black Faceplate	128
	PWR-SQ-W	Square Power Spec with White Faceplate	128

GENERAL INFORMATION

- Includes one simplex receptable
- 12' cord

REQUIRED INFORMATION: (ORDER CANNOT BE ENTERED WITHOUT THIS INFORMATION)

- See appendix pages vi-vii for surface material options.
- Choose Metal Finish: Satin Nickel (SNB) or Chrome (CB)

USB SPEC	MODEL #	DESCRIPTION	PRICE
 USBC-R-W	USBC-R-B	Round Data Spec with Black Faceplate	267
	USBC-R-W	Round Data Spec with White Faceplate	267
 USBC-SQ-W	USBC-SQ-B	Square Data Spec with Black Faceplate	267
	USBC-SQ-W	Square Data Spec with White Faceplate	267

GENERAL INFORMATION

- Includes one charging USB-A+C
- 6' cord

REQUIRED INFORMATION: (ORDER CANNOT BE ENTERED WITHOUT THIS INFORMATION)

- See appendix pages vi-vii for surface material options.
- Choose Metal Finish: Satin Nickel (SNB) or Chrome (CB)



POWER AND DATA OPTIONS

GROMMET	MODEL #	DESCRIPTION	DIAMETER	PRICE
	GR	Round Grommet	2" Dia	242



OPTIONS	CODE	PRICE	NOTES
Polished Chrome Grommet	Add -PCG	\$98 per unit	

GENERAL INFORMATION

- Available at center location only

REQUIRED INFORMATION: (ORDER CANNOT BE ENTERED WITHOUT THIS INFORMATION)

See appendix pages vi-vii for surface material options.

- Choose Metal Finish: Powder Coat, Clear Anodized or Polished Chrome (upcharge applies)

LOCATION CODES	TECH NODE	POWER SPEC	USB SPEC	ROUND GROMMET	LOCATION	QUANTITY OF UNITS TO ORDER
	TN-1	SP-1	SP-1	G-1	One at center	1
	TN-2	SP-2	SP-2		One at each end	2
	TN-3	SP-3	SP-3		One at center and one at each end	3
	TN-4	SP-4	SP-4		Four equally spaced	4

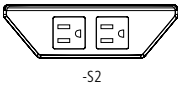
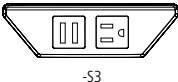

POWER AND DATA OPTIONS

HARDWIRE INFEED POWER RAIL KIT	MODEL #	TOTAL # OF RAILS	ELECTRICAL OUTLETS	(2) SIMPLEX -S2	ELECTRICAL OUTLETS	(1) SIMPLEX / (1) CHARGING USB -S3
(Includes Power Rails, Hardwire Infeed and Modular Power Components)  -S2  -S3	BJ-RAIL-1-H	1	2	1,462	1	1,462
	BJ-RAIL-2-H	2	4	2,320	2	2,320
	BJ-RAIL-3-H	3	6	3,177	3	3,177
	BJ-RAIL-4-H	4	8	4,036	4	4,036
	BJ-RAIL-5-H	5	10	4,894	5	4,894
	BJ-RAIL-6-H	6	12	5,749	6	5,749
	BJ-RAIL-7-H	7	14	6,605	7	6,605
	BJ-RAIL-8-H	8	16	7,461	8	7,461
	BJ-RAIL-9-H	9	18	8,321	9	8,321
	BJ-RAIL-10-H	10	20	9,179	10	9,179
	BJ-RAIL-11-H	11	22	10,035	11	10,035
	BJ-RAIL-12-H	12	24	10,892	12	10,892

GENERAL INFORMATION

- Includes modular power electrical system
- Hardwire infeed is 7' long
- Simplex receptacles will be white, when Burnished, Cloud or Foil powdercoat finishes are specified. Black simplex receptacles will be used for all other powdercoat finishes.
- Power Rails not available in Clear or Black Anodized

REQUIRED INFORMATION: (ORDER CANNOT BE ENTERED WITHOUT THIS INFORMATION)

See appendix pages vi-vii for surface material options.

- Choose Metal Finish

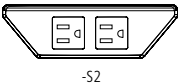
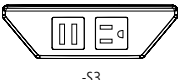
CORDED INFEED POWER RAIL KIT	MODEL #	TOTAL # OF RAILS	ELECTRICAL OUTLETS	(2) SIMPLEX -S2	ELECTRICAL OUTLETS	(1) SIMPLEX / (1) CHARGING USB -S3
(Includes Power Rails, Corded Infeed and Modular Power Components)  -S2  -S3	BJ-RAIL-1-C	1	2	1,589	1	1,589
	BJ-RAIL-2-C	2	4	2,450	2	2,450
	BJ-RAIL-3-C	3	6	3,306	3	3,306
	BJ-RAIL-4-C	4	8	4,161	4	4,161
	BJ-RAIL-5-C	5	10	5,018	5	5,018
	BJ-RAIL-6-C	6	12	5,879	6	5,879
	BJ-RAIL-7-C	7	14	6,736	7	6,736
	BJ-RAIL-8-C	8	16	7,591	8	7,591
	BJ-RAIL-9-C	9	18	8,448	9	8,448
	BJ-RAIL-10-C	10	20	9,307	10	9,307
	BJ-RAIL-11-C	11	22	10,165	11	10,165
	BJ-RAIL-12-C	12	24	11,021	12	11,021

GENERAL INFORMATION

- Includes modular power electrical system
- Corded single infeed is 7' long
- Corded Single Infeed option will require a 20amp outlet in the floor monument and reduces the modular electrical system in the table to a single circuit
- Simplex receptacles will be white, when Burnished, Cloud or Foil powdercoat finishes are specified. Black simplex receptacles will be used for all other powdercoat finishes.
- Power Rails not available in Clear or Black Anodized

REQUIRED INFORMATION: (ORDER CANNOT BE ENTERED WITHOUT THIS INFORMATION)

See appendix pages vi-vii for surface material options.

- Choose Metal Finish

DATA RAIL	MODEL #	DESCRIPTION	PRICE
 BJ-RAIL-DATA	BJ-RAIL-DATA	Data Rail includes (1) blank faceplate and (1) dual RJ-45 faceplate	664

GENERAL INFORMATION

- Data Rails not available in Clear or Black Anodized

REQUIRED INFORMATION: (ORDER CANNOT BE ENTERED WITHOUT THIS INFORMATION)

See appendix pages vi-vii for surface material options.

- Choose Metal Finish



POWER AND DATA OPTIONS

FIELD-WIRED	MODEL #	DESCRIPTION	(2) SIMPLEX -S2	(1) SIMPLEX / (1) CHARGING USB -S3
	BJ-RAIL-FW	Field-Wired Power Rail	764	764

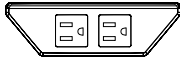

-S2



-S3

GENERAL INFORMATION

- Includes 6' flexible metal conduit and required a hardwire connection
- May be required in New York City, Chicago and San Francisco. Check with an electrician for local codes and requirements. A junction box will be provided when ordering the TW-RAIL-FW option.
- Power Rails not available in Clear or Black Anodized

REQUIRED INFORMATION: (ORDER CANNOT BE ENTERED WITHOUT THIS INFORMATION)

See appendix pages vi-vii for surface material options.

- Choose Metal Finish

INDIVIDUAL POWER RAIL	MODEL #	DESCRIPTION	(2) SIMPLEX -S2	(1) SIMPLEX / (1) CHARGING USB -S3
	BJ-RAIL	Power Rail	861	861

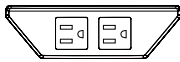

-S2

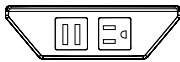

-S3

GENERAL INFORMATION

- Individual power rails do not include a modular power system. Each Power Rail must directly plug into a floor core with a 6'-corded 15-amp plug-in infeed. (Typically used with smaller tables, rounds, squares, soft squares, where a modular power system is not required.)
- Simplex receptacles will be white, when Burnished, Cloud or Foil powdercoat finishes are specified. Black simplex receptacles will be used for all other powdercoat finishes.
- Power Rails not available in Clear or Black Anodized

REQUIRED INFORMATION: (ORDER CANNOT BE ENTERED WITHOUT THIS INFORMATION)

See appendix pages vi-vii for surface material options.

- Choose Metal Finish



POWER AND DATA OPTIONS

SINGLE INFEED OPTION	MODEL #	DESCRIPTION	PRICE
	SI-H	Single In-Feed Option, Hard-wired	608
	SI-C	Single In-Feed Option, Corded (Plug-in)	734

GENERAL INFORMATION

- Tables 48" -96" in length include 2 duplex receptacles with the modular power system
- Hardwired and Corded Single Infeed options are 7' long
- Single Infeed option cannot be specified in conjunction with the Field-Wired (-FW) option

DATA FACEPLATES	MODEL #	DESCRIPTION	STYLE	W x H	PRICE
	FLDF-1	Blank faceplate, single height	Single	3-1/2 x 5/8	81
	FLDF-2	One VGA 15-pin HD Female to Female Gender Changer, one 3.5mm Stereo Mini Jack to Solder Tabs	Single	3-1/2 x 5/8	284
	FLDF-3	One VGA 15-pin HD Female to Female Gender Changer	Single	3-1/2 x 5/8	223
	FLDF-4	One RJ-11 Female to Punch Down - Phone	Single	3-1/2 x 5/8	223
	FLDF-5	One RJ-45 Female to Female Barrel - Data	Single	3-1/2 x 5/8	182
	FLDF-6	Two RJ-45 Female to Female Barrels, single height	Single	3-1/2 x 5/8	244
	FLDF-7	Two RJ-45 Female to Punch Down for CAT 6 - AMP	Single	3-1/2 x 5/8	345
	FLDF-8	Two RJ-45 Female to Punch Down for CAT 6 - Leviton	Single	3-1/2 x 5/8	345
	FLDF-10	Two RJ-45 Female to Punch Down for CAT 6 - Panduit	Single	3-1/2 x 5/8	345
	FLDF-11	Two USB A Female to Two USB A Female on 10" Pigtails	Single	3-1/2 x 5/8	386
	FLDF-12	Blank faceplate, double height	Double	3-1/2 x 1-3/8	101
	FLDF-13	Two RJ-45 Female to Female Barrels, double height	Double	3-1/2 x 1-3/8	244
	FLDF-14	Cable Pass-Through Set - one top, one bottom	Double	3-1/2 x 1-3/8	426
	FLDF-15	One HDMI Female to Female Barrel	Single	3-1/2 x 5/8	284

GENERAL INFORMATION

- Each BJ-RAIL-DATA unit holds two Single Space faceplates
- Faceplates are black

CHARGING TRAC	MODEL #	TOTAL BRACKETS	# OF USB PORTS	PRICE
	TRAC-2	2	4	2,216
	TRAC-4	4	8	3,738

GENERAL INFORMATION

- Plug-in Infeed only
- Field Installed
- 15 amp

REQUIRED INFORMATION: (ORDER CANNOT BE ENTERED WITHOUT THIS INFORMATION)

See appendix pages vi-vii for surface material options.

- Choose Metal Finish



POWER AND DATA OPTIONS

WIRE MANAGER	MODEL #	DESCRIPTION	PRICE								
<p>HPWM</p>	HPWM	Hoop Base Wire Manager	435								
	WFWM	Wire Frame Wire Manager	400								
<table border="1"> <thead> <tr> <th>OPTIONS</th> <th>CODE</th> <th>PRICE</th> <th>NOTES</th> </tr> </thead> <tbody> <tr> <td>Polished Chrome Finish</td> <td>Add -PCF</td> <td>\$516</td> <td></td> </tr> </tbody> </table>				OPTIONS	CODE	PRICE	NOTES	Polished Chrome Finish	Add -PCF	\$516	
OPTIONS	CODE	PRICE	NOTES								
Polished Chrome Finish	Add -PCF	\$516									
<p>GENERAL INFORMATION</p> <ul style="list-style-type: none"> If selecting Blackened Nickel base finish, choose Storm for Wire Management color 											
<p>REQUIRED INFORMATION: (ORDER CANNOT BE ENTERED WITHOUT THIS INFORMATION) See appendix pages vi-vii for surface material options. <ul style="list-style-type: none"> Choose Metal Finish </p>											

METAL WIRE CHASE COLUMN	MODEL #	DESCRIPTION	PRICE							
<p>BJCB-P</p>	BJCB-P	Wire Chase Column	1,250							
	<table border="1"> <thead> <tr> <th>OPTIONS</th> <th>CODE</th> <th>PRICE</th> <th>NOTES</th> </tr> </thead> <tbody> <tr> <td>Polished Chrome Finish</td> <td>Add -PCCB</td> <td>\$1,561</td> <td></td> </tr> </tbody> </table>			OPTIONS	CODE	PRICE	NOTES	Polished Chrome Finish	Add -PCCB	\$1,561
OPTIONS	CODE	PRICE	NOTES							
Polished Chrome Finish	Add -PCCB	\$1,561								
<p>GENERAL INFORMATION</p> <ul style="list-style-type: none"> To be used with (2) base tables (Not intended as a center support) Wire management opening is 9.75" x 6.375" Cannot be specified on 72"-long tables 										
<p>REQUIRED INFORMATION: (ORDER CANNOT BE ENTERED WITHOUT THIS INFORMATION) See appendix pages vi-vii for surface material options. <ul style="list-style-type: none"> Choose Metal Finish </p>										

TECH ZONE	MODEL #	DESCRIPTION	SIMPLEX OUTLETS	OPEN DATA PORTS	CHARGING USB-A+C	PRICE
<p>ZONE-USB-C</p>	ZONE-DATA	(2) Simplex receptacles, (2) Open data ports	2	2	-	375
	ZONE-USB-C	(2) Simplex receptacles, (1) Charging USB-A+C, (1) Open data port	2	1	1	449
<p>GENERAL INFORMATION</p> <ul style="list-style-type: none"> 72" long plug-in infeed cord Finish is black Includes a Voice/Data Adapter Kit to accept couplers and jacks when required 						
<p>ZONE-DATA</p>						
<p>ZONE-USB-C</p>						



Appendix



This price book supercedes all previous versions.

Before placing your order, confirm you have all required information necessary. Lead times for orders begin after all required information is included and correct.

Delivery Information

We know lead times are important and sticking to them even more so. We work to maintain a 6-8 week lead time on all standard products in this book from receipt of a clean order. All orders are acknowledged with an approximate shipping date and will be invoiced with the price in effect at the date the purchase order is received. For current lead times, please review www.nucraft.com/resources/lead-times.

Shipping charges are prepaid (within the continental U.S.). Therefore, pricing is a delivered price based on normal ground transportation. If you have special instructions, need to ship by air, or are shipping to Alaska or Hawaii, contact Nucraft Customer Service. Nucraft can also help arrange to have products blanket wrapped for an additional charge. Contact the Nucraft Customer Service team or specify it on your purchase order.

Minimum Freight Charge: Any order below \$3,000 net will be assessed a \$500 net minimum freight charge (one per order).

Orders are subject to acquiring the materials required for manufacturing. Fulfillment can be affected by strikes, fires, embargoes and acts of government. These elements are beyond our control.

Nucraft offers a variety of services to accommodate a wide range of delivery requirements. Availability of these services is dependent on a number of factors and may not be offered with all shipments. Examples of delivery services that have additional fees include:

- Specific date
- Specific time of day, morning or afternoon
- Delivery to a warehouse before delivery to its final destination (unless product is picked up at the warehouse)

Contact the Nucraft Customer Service team for availability and pricing on these services.

Freight Terms

Shipping charges for Nucraft products are prepaid for standard delivery in the continental United States. Standard delivery is defined as follows: Product is delivered on a 53' trailer being pulled by a long-haul tractor (total length of 85'). Facility will receive delivery Monday through Friday between the hours of 8:00 AM and 4:00 PM. Facility has docks with levelers and a fork truck for unloading. Product will be loaded on load bars two levels high. Receiving facility is responsible to have personnel on hand to unload the truck upon arrival, drivers do not unload. Delivery sites or times that do not meet these criteria may be accommodated, but will incur a charge to cover additional shipping costs. Please **notify Nucraft a minimum of two weeks prior to shipment** to arrange special services and determine additional charges.

Storage

Nucraft has no storage facilities for finished product. If a customer cannot accept an order when it is ready for shipment, the customer must designate an alternative shipping address. If no address is provided, Nucraft may, at its discretion, transfer the product to storage. If product is transferred to an off-site storage facility, the customer may be charged for transportation to the facility and for any associated storage fees. Nucraft considers transfer of the product to a storage facility the equivalent of shipment, including invoicing and payment. Customers assume the risk of damage or loss during storage.

Transportation Times and Delays

Third party carriers that Nucraft contracts with will make reasonable efforts to accommodate requested delivery times and dates. Scheduled delivery appointments may, however, be delayed for a variety of reasons, including inclement weather, traffic, transportation equipment problems, and delays encountered at other delivery locations along the delivery route. Nucraft does not recommend scheduling activities that depend on the delivery appointment (for example, scheduling furniture installers to install furniture the day of the delivery appointment). Nucraft shall not be liable for any costs incurred as a result of a missed delivery appointment.

Shipment Damage Claims

Legal title to merchandise passes to the buyer upon acceptance by the carrier. Inspect all cartons upon delivery. Details of visible damage should be noted on the delivery receipt. Do not destroy packaging, transport to site, or install product if damage is found upon inspection. Inspection of products should be completed upon delivery to the receiver. If visible damage is apparent, a claim should be filed immediately with Nucraft Customer Service. If visible damage is not apparent, sign the delivery receipt "No visible damage." This will allow recourse for a concealed damage claim. Concealed damage claims must be filed within 15 days of receipt, **prior to transporting or installing any product.**

Do not destroy packing materials until shipment has been inspected. If damage is found, proceed to file a claim with Nucraft Customer Service.

Failure to make any claims against Nucraft within 15 days shall constitute acceptance of the merchandise and a waiver of any defects, errors or shortages discovered upon inspection.

Cancellations

Cancellations must be reviewed by our Customer Service team. Because we build your products to order, orders cannot be cancelled once processing has begun. Processing includes but is not limited to development of shop drawings and other engineering drawings. If cancellation is approved, a processing fee of 20-100% will be assessed based on the status of the order.

Change Order Policy

Nucraft will make every attempt to honor any reasonable change request to product provided that the request is received prior to start of production. Change orders will be accepted only if the request is made in writing and received in time to make the change. Nucraft reserves the right to increase our acknowledged price and ship date if necessary to make the requested changes. Please submit any change order request to our Customer Service team. Nucraft will assess charges to the customer as stipulated in the following:

- Standard Orders: Change orders received prior to production will be charged \$400 net to cover administrative costs.
- Special Orders: Change orders received prior to production will be charged \$400 net to cover administrative costs. There may be additional costs associated with engineering labor required for the change order.
- Change orders received after production must be evaluated by Nucraft. If approved, the charge will be \$400 net plus any restocking charges accumulated. There may be additional costs associated with engineering and/or manufacturing labor, as well as material costs, required for the change order.



Repair Authorization

Prior written approval is required for repairs of merchandise charged to Nucraft. Failure to do so will result in customer funded repairs.

Payment Terms

Deposits are required at the time of order due to the custom nature of our products. See information regarding Cancellations above.

Credit terms are available to qualified customers. Please contact AR@Nucraft.com to start the application process. Note that the credit application process requires a valid sales tax exemption or resale tax certificate, Form W-9, and three current trade references.

Credit Card Payments are accepted via web portal. Please contact AR@Nucraft.com for payment instructions. Note that a 2% convenience fee will be added for using this payment method and no early pay discounts are allowed on credit card payments.

Warranty

Nucraft Furniture is warranted to be free from defects in materials and workmanship for a period of ten years of single shift use. Limitations include:

- Mechanical Devices such as latches, casters, and other moving components are warranted for five years of the date of original delivery.
- Height adjustable components are warranted for two years of the date of original delivery.
- The following are warranted for one year of the date of original delivery:
 - Textiles
 - Electrical Components
 - Refrigeration Units
 - Custom Products not described in Nucraft's Catalogue

This warranty is applicable only if furniture is properly installed and maintained in an office environment. This warranty extends only to products manufactured and sold in North America and only to original purchasers acquiring new Nucraft product through authorized dealers or approved sellers.

During this warranty period, Nucraft's sole obligation is to repair or replace, at Nucraft's discretion, products which prove to be defective during the warranty period.

This warranty does not cover:

- Damage caused by a carrier.
- Damage from user modification, misuse, abuse, accident, or negligence.
- Customer's Own Material (COM) specified by the customer that is not a standard product offering.
- Color, grain, or texture of wood and other covering material.

Nucraft extends no other warranties, expressed or implied, including warranty of merchantability or fitness for a particular purpose. Nucraft shall not be liable for loss of time, inconvenience, commercial loss, incidental or consequential damages.

Environmental Statement

Nucraft is committed to supporting responsible environmental policies and practices in all that we do. We strive for sustainability, weighing our business decisions against the costs to the ecological, social and economic systems they affect.

Our products are manufactured to meet the credit requirements of the U.S. Green Building Council's LEED rating systems in one or more of the following categories:

- Recycled Content
- Certified Wood
- Low-Emitting Materials

Computer Aided Planning

Nucraft products and pricing are available via CET and 2020 Worksheet, an AutoCAD®-based space planning tool.

2020 Worksheet is an integrated software system developed specifically for interior designers and facility planners to enhance workplace performance. This modern suite of applications works together seamlessly, in concert. Navigate catalogs, select products, design in plan view and 3D, assign options, create worksheets and build a project where you want, when you want. Take your pick. It's dynamic and interactive. Design projects are a work in progress. And now you can perform any of the many discrete tasks that go into a project any time, any place.

Product symbols (Revit, 2D and 3D) are available on the Nucraft website at www.nucraft.com/resources/designer-tools/product-symbols.

iSpec®

Nucraft offers a free online product configuration and specification service that saves you time and allows you to be creative while leaving the nuts and bolts to someone else. No specific software is required, nor is there any learning curve. This service applies to all Nucraft products. For additional information, visit www.nucraft.com/resources/designer-tools/ispec.



Surface Materials Palette

We crafted our materials palette using the same demanding standards that distinguish our furniture. Thoughtful design and attention to every detail elevate your possibilities.

Anchored by Nucraft veneers, unrivaled for clarity, quality, and depth of finish, our collection of surface materials comprises a sophisticated set of balanced elements that supports your design vision.

Some elements have their roots in Nucraft's rich heritage. Others are new materials and reflect current trends and taste. Together, they ensure that you're ready for today and positioned well for the future. Beautifully.

Custom Finishes

Nucraft specializes in expert custom finish matching. For a nominal upcharge we can provide custom finishes, and we are frequently asked to match the finishes of other furniture manufacturers. For finishes that appear unusual to match or for customers directly requesting a sample, a finish sample will be sent for approval prior to entering the order.

Custom finishes requiring colored varnishes to create a painted look can only be applied to Maple veneer and require one extra week in addition to the standard lead time. Nucraft's standard black finish (G82) can be applied to all Nucraft standard veneers. Walnut is the standard black veneer. Other species must be specified when ordering.

Clear coat on a special veneer requires an approved sample.

Custom finishes carry a 10% upcharge per item, per finish, capped at \$2,200 List.

Custom finish upcharges are not applied to any item that is not wood. Example: casters, ganging connectors, power options..

Treatments

Note: Default veneer sheen will vary per finish and product. Default finish is bolded on pages vi-vii. If no direction is provided on incoming orders, default sheen will be selected. In addition, default veneer cut is noted in the price list. If no direction is provided on incoming orders, default cut will be selected.

Gloss: Gloss is a durable finish that tends to nicely mask normal wear and leaves wood grain visible to the eye. It achieves a medium gloss open pore appearance (40 – 50 sheen range). Finish numbers preceded by the letter "G" indicate a Gloss finish.

Matte: Like Gloss, Matte is durable, tends to nicely mask normal wear and leaves wood grain visible to the eye. It achieves a low luster, open pore appearance (10 – 20 sheen range). Finish numbers preceded by the letter "M" indicate a Matte finish.

Since each veneer type responds differently to both types of treatment, all will have a distinctive look and feel when finished. For example, a Walnut veneer with a Gloss treatment will remain much more textured than a Cherry veneer with the same treatment.

About the Wood

All Nucraft veneers are carefully selected for uniformity of color and grain. Still, wood is a natural substance and minor variations may occur due to its own uniqueness. Because of this, the furniture you receive may not be an exact match to our samples.

Nucraft takes great pride in our finish color consistency. However, wood is a natural product that will have color variation within a single piece of furniture, as well as from one piece to the next. Other factors also affect color over time, such as exposure to light (both intensity and duration). For example, lighter finishes cause more variation in colors over time.

In cases where a returning customer wants a precise match with existing furniture, we recommend sending a sample of the existing furniture finish. Please contact Nucraft Customer Service to determine an appropriate sample. This will ensure a finish match between old and new orders. This type of order is considered a control sample. There will be a 10% upcharge on an order of this type. Due to natural aging of veneers, natural finishes may vary.

Care and Maintenance of Wood Finishes

Our finish material is a crystal clear, urethane acrylic blend. This type of finish may be repaired in the field by a qualified refinisher.

Nucraft recommends using a damp cloth to clean your fine wood furniture. Always wipe with the grain of the wood. Should your wood furniture require a more thorough cleaning, we recommend using a mild cleaner such as Joy dish soap or Murphy's oil soap, thoroughly diluted in water (one part soap to thirty parts water). Water will not damage Nucraft's finish, but it may leave surface spots when it dries. To avoid this, dry the surface with a soft cloth after it is cleaned. Marks that cannot be removed with the cleaning methods above may be able to be removed using naphtha, a mild degreasing solvent.

Caution: while the use of polishes that contain wax, petroleum solvents or silicones may immediately enhance the "shine" of a product, it may also eventually remove the fine original finish applied in our factory. Silicone on the surface of wood may also make it very difficult to respray or refinish.

All Nucraft furniture is inspected and polished before it leaves our factory. In some instances, the packing materials may imprint on the factory polish. Cleaning and polishing the furniture once it is unpacked will normally restore the furniture to its original beauty.

In some cases, the rubber support feet used on the bottom of common office equipment (teleconferencing phones, laptops, microphones, copiers, etc.) can create unsightly marks in the surface of wood tops, due to oxidation of the lacquer finish. We suggest these machines be placed on a protective type of padding, such as felt.

Wood will fade as a result of exposure to UV light. This is particularly prevalent with light finishes. If color changes due to fading are a concern for your application, the impact can be minimized by selecting medium to dark stains for your wood surfaces. Our top coat includes a UV inhibitor which makes the finishes less prone to fading.



Laminates

Selected Formica®, Nevamar®, and Wilsonart® laminates are available on Training Tables, Conference Tables, Conference Room Furniture and select Occasional Tables. For standard laminate and wood pricing, refer to individual item pricing columns. It is important to note that wood grain laminates are unable to be grain matched over multi-piece table top applications.

Non-Standard Laminates and Linoleums

To order a color other than those on our list (see pages vi-vii), refer to Nevamar or Formica standard grade, matte texture laminate offerings and Forbo Furniture Linoleums (excluding manufacturers' non-standard matte offering).

Nucraft can support other laminate and linoleum options beyond what can be found as standard options on pages vi-viii. For pricing, please send a request to quotes@nucraft.com.

Care and Maintenance of Laminate and Novawrap

Laminate and Novawrap surfaces may be cleaned with a damp cloth and ordinary soap or non-abrasive household liquid detergent. Dry the surface with a clean cloth or soft paper towel to prevent streaks from appearing.

Care and Maintenance of Metal

Metal surfaces can be wiped with a damp cloth and rubbed dry. A mild non-abrasive household liquid detergent can be used if necessary. Regular maintenance of metal components, including tightening of fasteners and light lubrication of moving parts, will extend the life of your furniture.

Satin Etched Glass

Glass color may vary slightly on multi-piece conference table tops over 180" x 60" when satin etched glass is specified due to the iron content and etching process of the glass.

Care and Maintenance of Glass

Clear or frosted glass may be cleaned with commercial glass cleaner. Be sure to use a lint-free cloth if cleaning the frosted side of the glass.

Stone and Solid Surface Material

Despite its reputation for durability, natural stone can easily be broken during handling and/or installation if proper techniques are not followed. In addition, Nucraft is not responsible for the installation of natural stone or solid surface materials on its products. Therefore, installers specifically trained in the installation of these materials must be utilized to ensure a quality installation. Nucraft shall not be liable for any damages incurred during the handling and/or installation of natural stone or solid surface materials on its products.

Care and Maintenance of Granite

Granite surfaces may be cleaned with a damp cloth and ordinary soap or non-abrasive household liquid detergent. Dry the surface with a clean cloth or soft paper towel to prevent streaks from appearing.

Care and Maintenance of Leather

Genuine leather requires very little care. Nucraft recommends that leather be dusted regularly. If a more thorough cleaning is needed, use lukewarm water and a mild, non-abrasive soap. Generate some lather and lightly rub the surface with cheesecloth. Rinse off any soap film with clean water and towel dry. The leather may dry dull. To restore the leather to a normal gloss, rub it with a clean towel. Never use furniture polish, oil, varnish or ammonia. Saddle soap may be used to prevent the leather from becoming brittle or cracked and to maintain the original supple finish.

Touch Up Finish Kits

Model #	Description	Price
KIT-M	Metal Kit	85
KIT-P	Paint Kit	85
KIT-S	Stain Kit	85

REQUIRED INFORMATION:

(ORDER CANNOT BE ENTERED WITHOUT THIS INFORMATION)

- Kit model number
- Quantity of kits
- Specify finish (See pages vi-vii)

General Information:

- Touch-up kits must be ordered on a purchase order separate from Nucraft product due to Hazmat shipping

Retrofit & Replacements

If needing a partial placement or retrofit solution, please reach out to our quote team. Grain/color matched in a set.



veneer

STANDARD

Default veneer sheen will vary per finish and were determined by a team of experts who reviewed the colorways to determine if gloss or matte best highlighted the natural characteristics of the species of wood and the color of the stain. Default finish is bolded. If no direction is provided, default sheen will be selected.

	Matte	Gloss
Rift Cut Oak		
Carbon	M03	G03

Flat Cut Oak

	Matte	Gloss
Artisan	M68	G68
Coco	M67	G67
Dove	M66	G66
Dune	M05	G05
Midnight	M69	G69
Portobello	M7413	G7413
Winter	M70	G70

Flaky Oak

	Matte	Gloss
Sahara	M61	G61

Cherry

	Matte	Gloss
Auburn	M93	G93
Cognac	M21	G21

Walnut

	Matte	Gloss
Marron	M35	G35
Mocha	M33	G33
Onyx	M82	G82
Otter	M31	G31
Zinc	M30	G30

Maple

	Matte	Gloss
Natural Maple	M60	G60

Linea

	Matte	Gloss
Euro Birch Linea	M09	G09
Oak Linea	M08	G08
Silver Birch Linea	M10	G10
Walnut Linea	M27	G27

Paldao

	Matte	Gloss
Canyon	M77	G77
Paldao	M76	G76
Thicket	M75	G75

PLANK

Plank offers dramatic variations in veneer leaf color, length, and natural characteristics; it simulates randomly matched veneers.

	Matte	Gloss
Plank Walnut		
Clear Coat	M38	G38

LAMINATE

Coordinating wood finish and edgeband options listed below.

		Solid Edge Band
Solid Laminates		
Formica Brite White	459-58	R01
Formica Dover White	7197-58	R01
Formica Folkstone	927-58	R03
Formica Graphite	837-58	R05
Formica Graystone	464-58	R02
Formica Pearl	934-58	R02
Patterned Laminates		
Nevamar Calm Distinction	VA6001T	R05
Nevamar Cool Chic	VA7002T	R02
Nevamar Easy Elegance	VA5002T	R05
Nevamar Serene Stardom	VA5001T	R05
Wilsonart Sheer Mesh	4876-38	R02
Wilsonart Grey Mesh	4877-38	R02
Wilsonart Pewter Mesh	4878-38	R05

		Wood Finish	Woodgrain Edge Band
Wood Grain Laminates			
Formica Aged Ash	8844-58	M8844	R8844
Formica Blackened Legno	8848-58	M8848	R8848
Formica Bleached Legno	8845-58	M8845	R8845
Formica Chestnut Woodline	5884-58	M5884	R5884
Formica Espresso Pear	5489-58	M5489	R5489
Formica Natural Ash	8843-58	M8843	R8843
Formica Oiled Legno	8846-58	M8846	R8846
Formica Pecan Woodline	5883-58	M5883	R5883
Formica Planked Coffee Oak	7413-58	M7413	F7413
Formica Sand Maple	9237-58	G60	W7909
Formica Smoky Brown Pear	5488-58	M5488	R5488
Formica Thermo Walnut	6402-58	M6402	R6402
Formica Urban Planked Oak	9312-58	M9312	R9312
Formica Weathered Ash	8842-58	M8842	R8842
Formica White Ash	8841-58	M8841	R8841

GLASS

	Satin	Gloss
Satin or Gloss Glass		
Black	BS	-
Clove	VS	VG
Meringue	MS	MG
Moonlight	MLS	MLG
Storm	STS	STG
Quill	QS	QG
White	WS	WG

Note: Due to color variation inherent in the natural acid etching process, Satin Etched Glass is not available on tables longer than 180" or wider than 60".



METAL

Powder Coat

Aged Bronze		A8010
Black		A44
Burnished		A8009
Cloud		A8004
Foil		A8006
Galaxy		A8007
Moonlight		A87
Satin Bronze		A8011
Shadow		A8005
Storm		A8012

Metal

Blackened Nickel	(upcharge applies)	ABN
Clear Anodized		CA
Polished Chrome	(upcharge applies)	PC
Satin Chrome	(upcharge applies)	SC

PAINT

Aged Bronze		S8010
Black		S44
Burnished		S88
Cloud		S8004
Foil		S8006
Galaxy		S8007
Moonlight		S87
Satin Bronze		S8011
Shadow		S8005
Storm		S8012

Paint to Match

To request a custom paint color, contact Nucraft Customer Service.
A paint sample must be matched and approved prior to order.

EDGE BAND

Ashen		R04
Parchment		R02
Shale		R05
Stone		R03
Whitecap		R01