

NUCRAFT

Flow NT Installation Instructions

ID:

Before Beginning Installation

- Read through the entire instruction thoroughly
- A minimum of 2 persons is required for this assembly
- These instructions reflect typical assemblies. They may not match your specific configuration.

Required Tools

- Drill Driver
- #2 and #3 Phillips Bit
- Phillips Head Screwdriver
- ¼" Allen Wrench
- 1/8" Allen Wrench
- 5/32" Drill Bit
- Level
- Draw Tight Fastener Tool (included)

Required Hardware

- Bolt – 3/8" UNC x 5/8" L-HW2248
- Screw – 10-12 x 1-1/4" PHIL
- Screw - #12 x 1" PAN-PHIL
- Draw-Tight Hardware
- Bolt – 5/16 – 18 x 5/8 Fit Socket Head Cap (Post Leg Base Only)

Flow NT Table

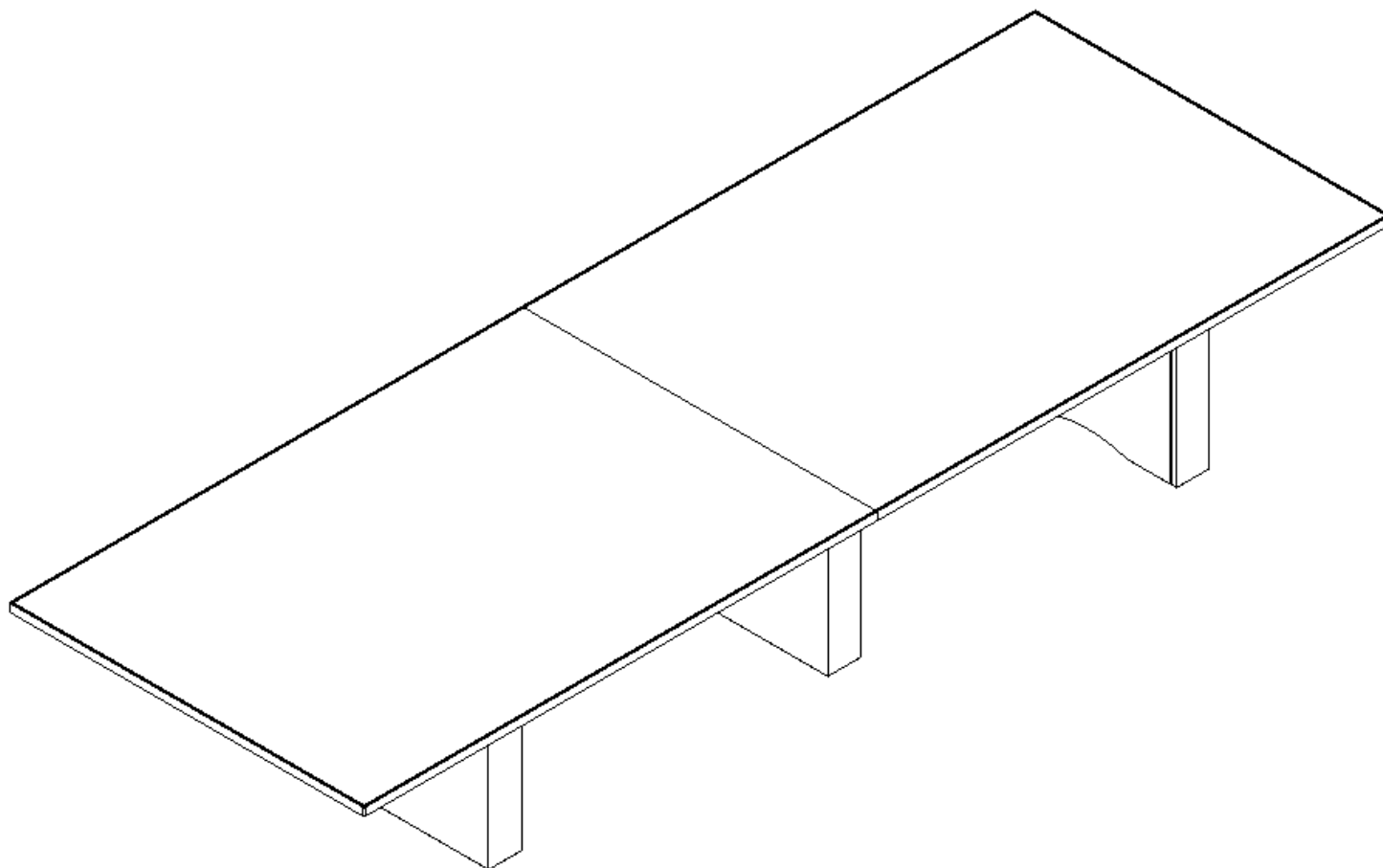

Flow NT Table Exploded

1. Top
2. End Base
3. Center Base
4. Main Beam

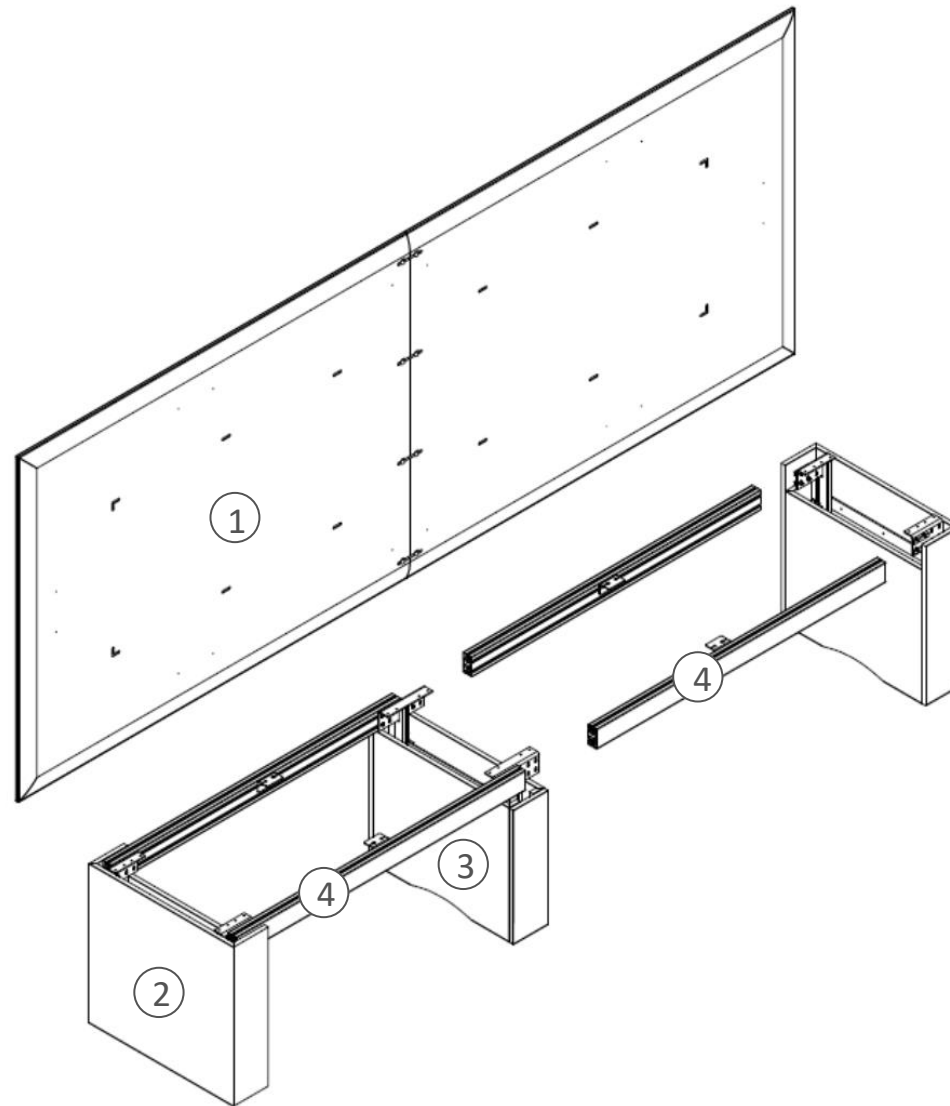

Installation Prep – 3-Piece and 4-Piece Tops

- 3-Piece and 4-Piece tops include gussets for extra support.
 - Locations are marked on the main beam.
- Slide the gusset's clamp bar onto the main beam BEFORE attaching the beam to the bases (facing outward).
- Tighten the 5/16 – 18 hex bolts.

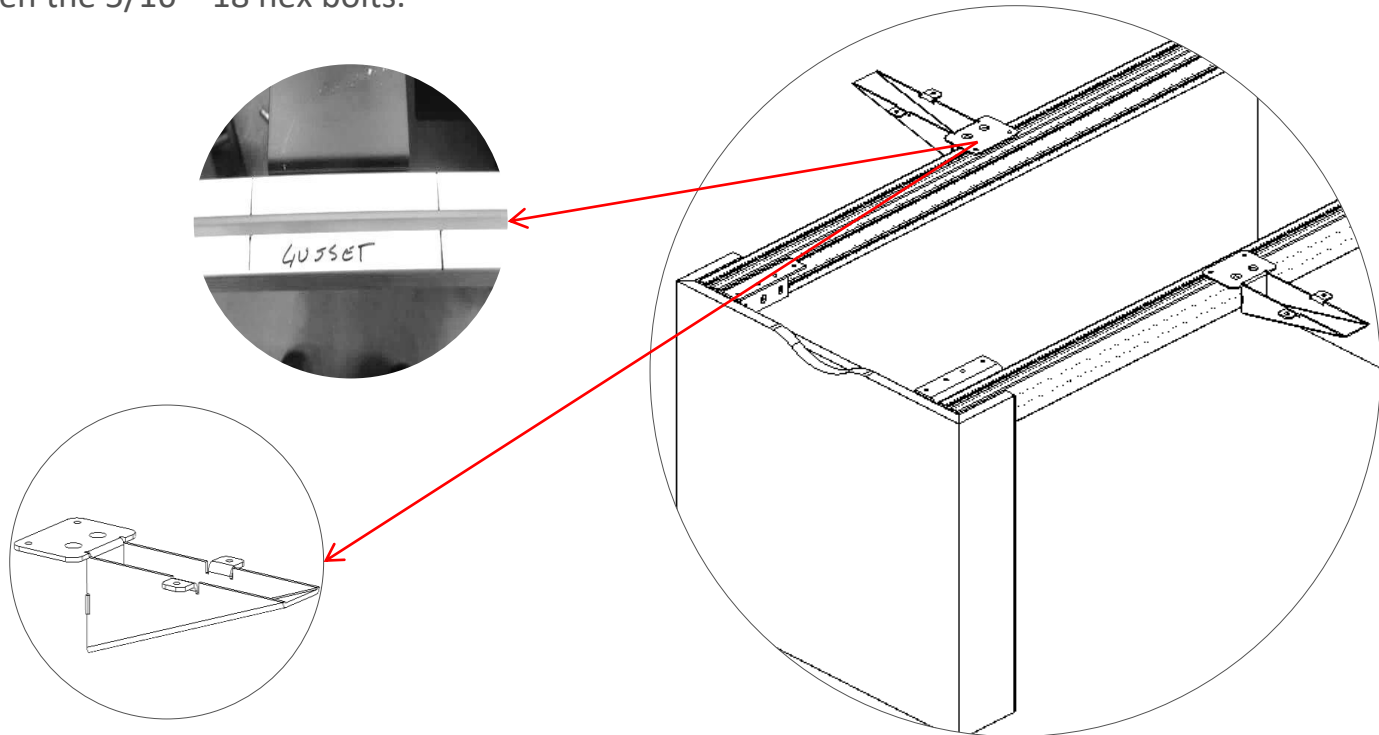

Step 1: Tables over 120"

- Locate beam labels and match for correct placement of bases.
- Loosen clamp bars from base.
- Attach end bases by sliding the clamp bars into the beams.
 - **Beams to be 1/8" minimum from the top of the base panel to ensure proper support.**
- Tighten cap screws to secure.
- Repeat to attach beams to center base. Keep beams tight and flush at the joint.

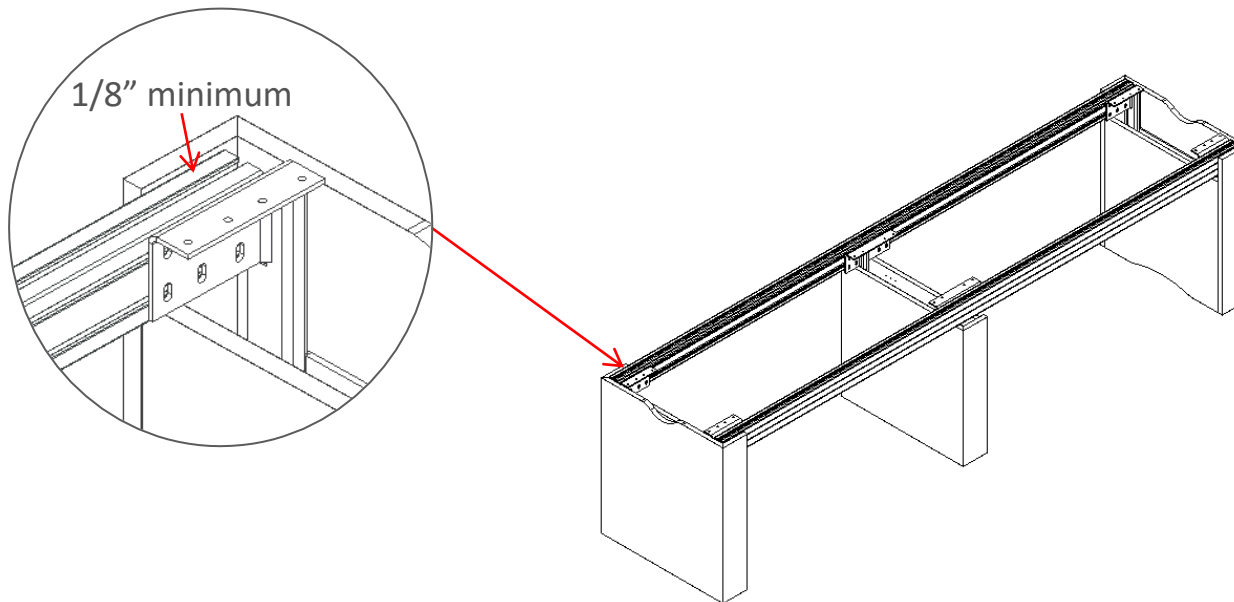

Step 5: Work Surface Alignment

- Use a level and adjust glides on the bottom of the bases to level table frame before adding the top.
- Align the “L” shaped notes on the bottom of the top with the corners of the bases.
- With multi-piece tops, join the pieces with the provided draw tight hardware.
- Fasten the work surface with the 1” #12 screws and brackets provided.

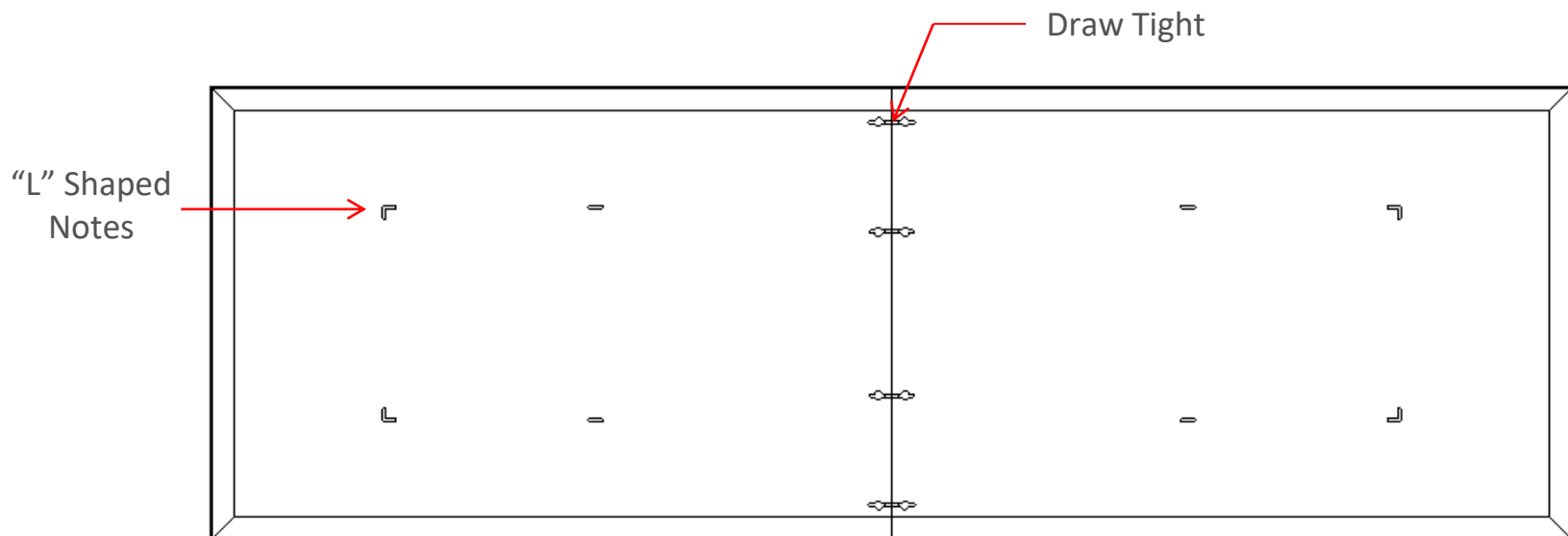

Flow NT Table – Post Leg Base

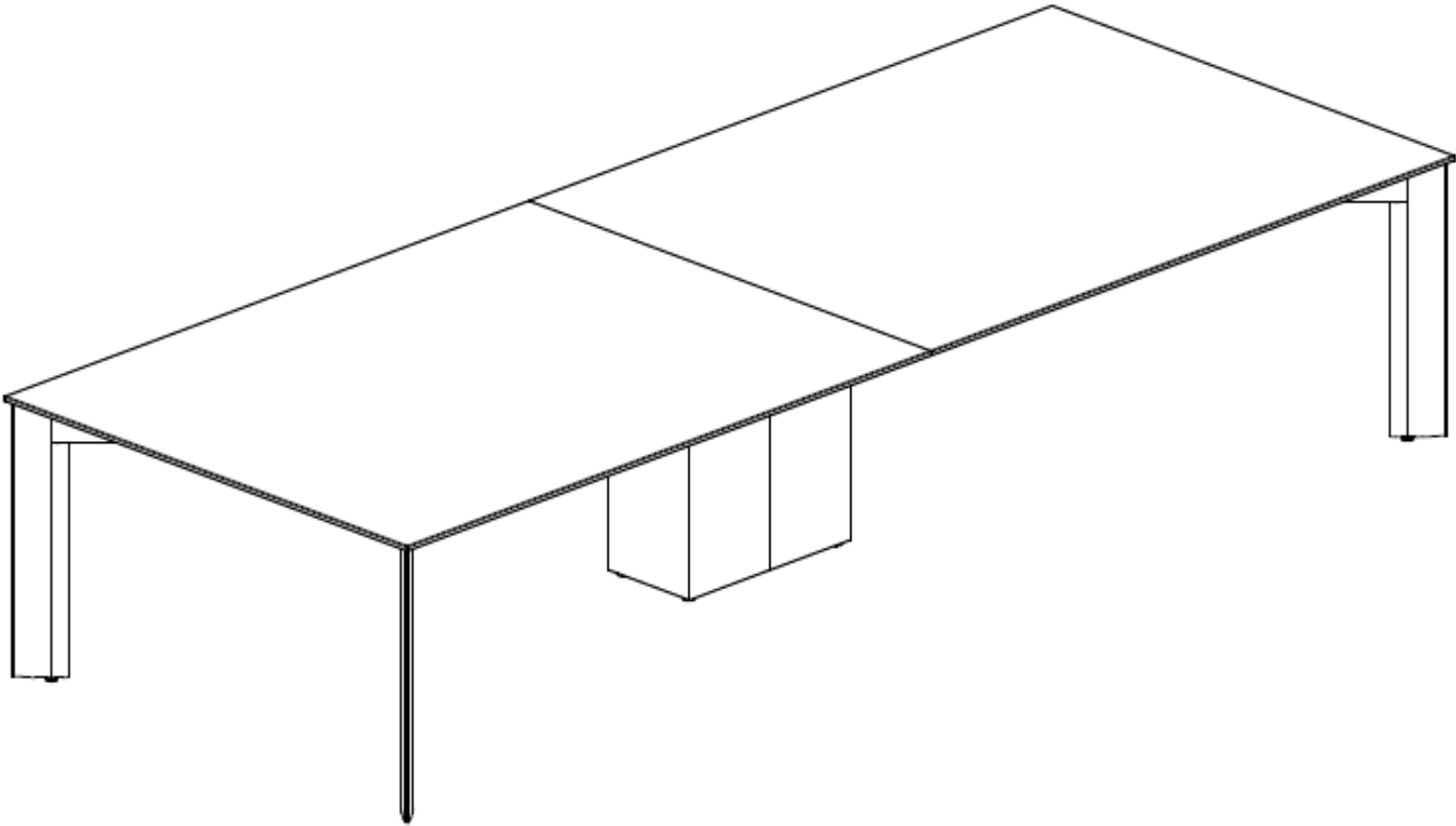

Flow NT Table – Post Leg Base

1. Top
2. End Base
3. Center Base
4. Main Beam

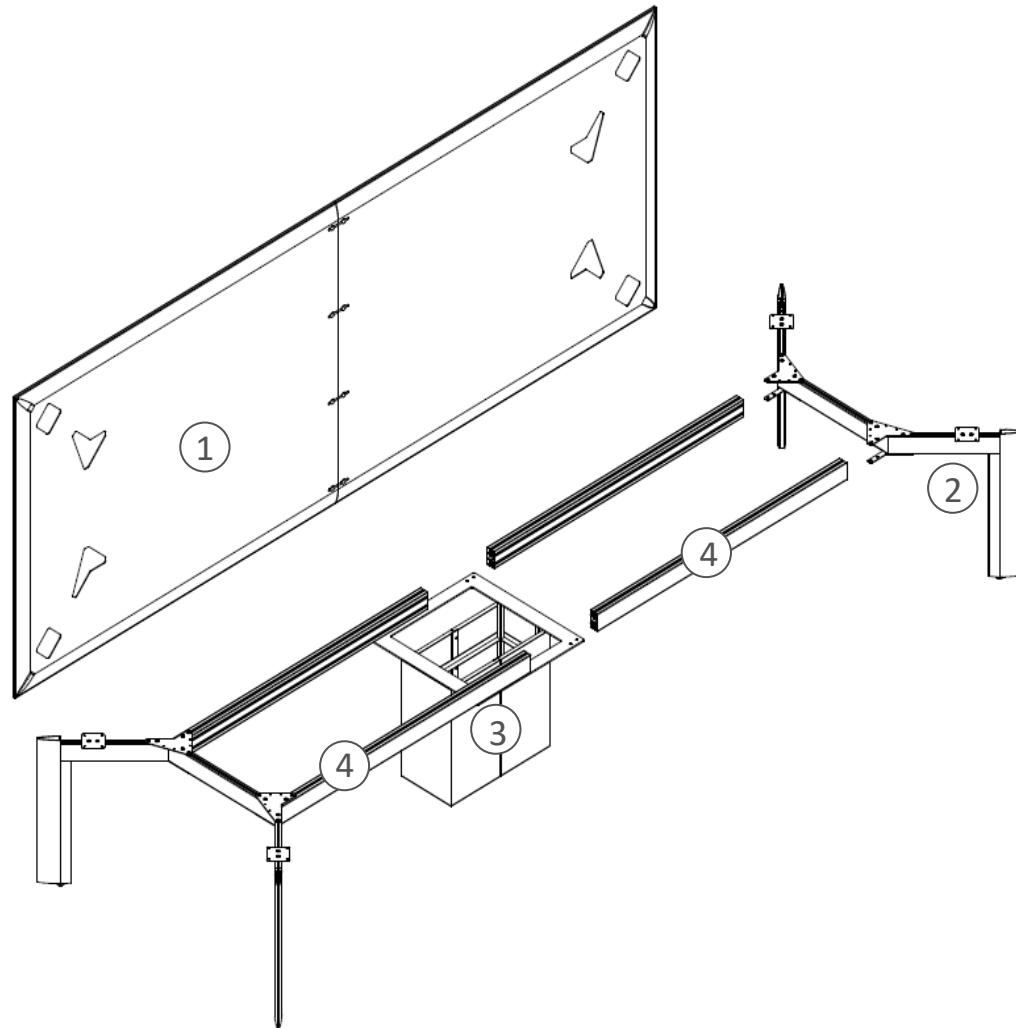

Installation of Post Leg Base

- Slide the clamp bars from the end base into a beam.
- Tighten the screws that fasten the end base to the beam.
- Then continue with Step #2 in instructions above.

