

KAI™

GSA Planning Guide + Price List

QUICK LINKS

[PLANNING GUIDE](#)

[KAI PRICING](#)

[POWER AND DATA OPTIONS](#)

[GENERAL INFORMATION](#)

[FINISH INFORMATION](#)

[SURFACE MATERIALS](#)



TABLE OF CONTENTS

Click the shortcuts below to jump to each section.

General Information	ii-iii
Finish Information	iv-v
Surface Materials	vi-vii
Statement of Line	3
Specification Overview	4
Planning Guide	5-15
Kai Tops and Bases	16-19
Power and Data Options	20-25

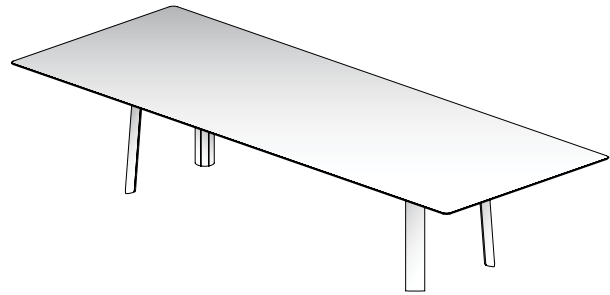



STATEMENT OF LINE

CONFERENCE TABLES

Pages 16-19



Rectangle

BASES

Pages 16-19



Metal Legs

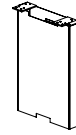

Rectangle Base



SPECIFICATION OVERVIEW

CONFERENCE TABLES

1. Select the Top Size and Shape

Kia conference tables are available in a Rectangle shape. Sizes range from 84" – 240" long and multiple widths.

2. Select Base Style and Finish

Kai tables are available with either Metal Legs or Rectangle Bases. The Metal Legs are available in powder coat, clear anodized aluminum and polished chrome finishes. The Rectangle Base is available in powder coat finishes. Tables longer than 168" include an elliptical-shaped center base.

3. Select Power Option (if desired)

Kai tables feature two power and data connectivity options:

- Table Top – Power Matrix, available with grain-matched wood, metal or glass doors, and offered in several locations and quantities per table.
- Under Surface – Power Rail, available in three configurations:
 - Two simplex receptacles
 - One simple receptacle and one powered USB-A+C connector
 - A/V faceplate designed for use with two single space Modular AV Inserts/Plates

TOP OPTIONS AND CAMBER RAIL

TOP OPTIONS

Kai tables are offered with two top material options:

Veneer/Aluminum Top

This option features a wood veneer surface and utilizes 5/16"-thick aluminum for a rigid, yet lightly scaled silhouette. The underside of the aluminum table edge features a gentle radius and is polished. The veneer surface is bonded to the aluminum top utilizing a proprietary process, and extends to the edges of the top.

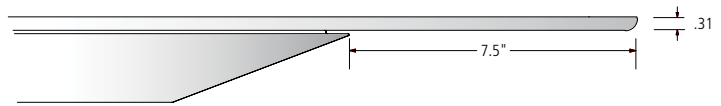

Glass Top

This option features 3/8"-thick, back-painted, optically clear glass with a pencil edge profile.

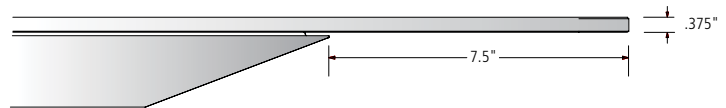

The support structure for both top material options is set back 7-1/2" from the table top edge, making it virtually unnoticeable and resulting in an ultra-thin top design.

CAMBER RAIL

Much like the elegant, yet highly visible, structural elements of a suspension bridge, the Camber Rail design of Kai displays both an engineering innovation as well as an iconic design element of the table while providing unexpected benefits.

Consisting of four camber rails made from thin steel tubes and twin heim joints, the camber rail design is a mechanical articulating joint that provides tension at the center of the table resulting in an extremely strong and flat table top. By rotating the camber rail spindle during installation, tension is placed on the rods until the table top is flat, thus ensuring the most robust frame structure for the table top. In addition to the aesthetic enhancement it gives to the table, the camber rail eliminates the need for a center base on tables up to 168" long, thus maintaining the minimalist appearance on large conference tables and eliminating the cost of the third base. The camber rail assembly is not present on tables 96" and shorter.

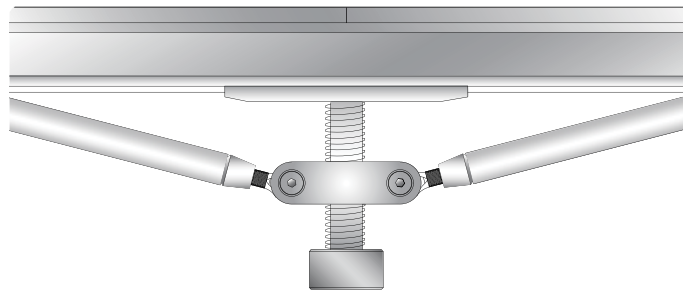



BASE OPTIONS AND WIRE MANAGEMENT OPENINGS

BASE OPTIONS

Kai tables are available with two base styles:

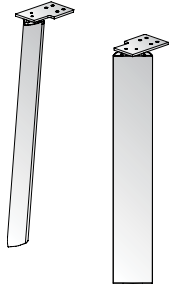

METAL LEG

This base style features a minimalist design while providing modest storage for routing cables from the floor to the table top via a removable cap in each leg. The Metal Leg option is available in multiple powder coat finishes as well as clear anodized aluminum and polished chrome.



RECTANGLE BASE

This metal base features enhanced internal capacity for routing cables via removable panels. The Rectangle Base is available in multiple powder coat finishes.



CENTER BASE

On tables longer than 168", this elliptical-shaped metal base is standard and provides additional support while also providing a means of routing cables from the floor to the table top via removable panels.

BASE DIMENSIONS

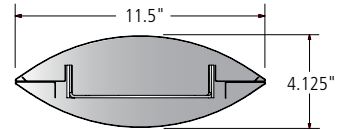
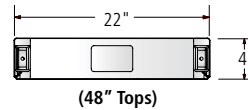
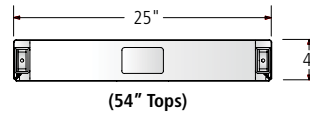
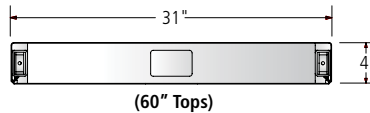
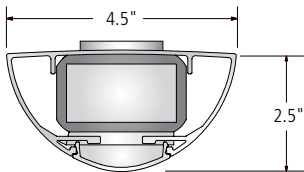

WIRE MANAGEMENT OPENINGS

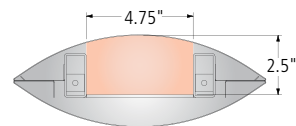
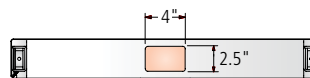
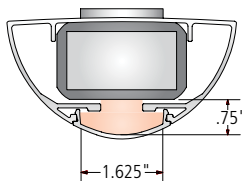

TABLE TOP POWER OPTION: POWER MATRIX

POWER MATRIX SMALL

For table top access with options for grain-matched wood, metal or glass doors, Power Matrix is offered in various quantities based on table length and location choice.

When Power Matrix is specified on a Kai table, a two-circuit electrical system with hardwired in-feed is included with the table. A direct plug-in in-feed is also available as an option.

Two-Circuit Electrical System

With either of the Kai power & data connectivity options, a two-circuit electrical system is available with the table. You can choose between a hardwired or plug-in infeed option. If the direct plug-in connection option is selected, all outlets will be on a single circuit.

- 4-wire, 20-amp, 2-circuit modular electrical system.
- All tables are pre-wired.
- When specified with the hardwired in-feed, a licensed electrician is required to complete hardwire connections to building's power source. The hardwire power infeed is 42" long.
- Neutral (white) wires are 10 gauge, hot and ground wires are 12 gauge.
- All electrical components satisfy National Electrical Code (NEC) requirements and are UL listed.

Cable Management

Kai provides multiple options for bringing cables from floor monuments into the table:

- Metal Leg – each of the four legs on a table include a channel with removable cap for routing cables.
- Rectangular Base Interior – when the rectangular base style is selected, its interior cavity provides generous capacity for cables via removable covers
- Center Column Base - standard on tables longer than 168", this elliptical-shaped metal base offers generous capacity for cables, accessed via removable covers. This base includes 6" of adjustment along the length of the table and 3" of adjustment across the width of the table to assist in locating over a floor monument.
- Wire Chase – this elliptical-shaped metal enclosure is a non-structural component that can be placed anywhere along the centerline of the table between the two bases and includes 3" of adjustment across the width of the table, providing great flexibility for locating it directly over a floor core, or to be removed altogether when future cable needs are eliminated (i.e., conversion to wireless).

Integrated wire management channels are included inside the table support frame to neatly and covertly manage cables beneath the table top.

Power Matrix Small

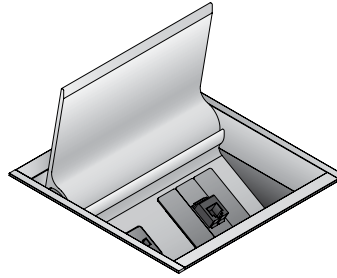

Electrical Diagram — Hardwire Power Infeed Only

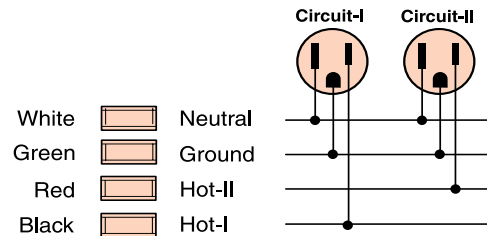

Metal Legs with Wire Chase

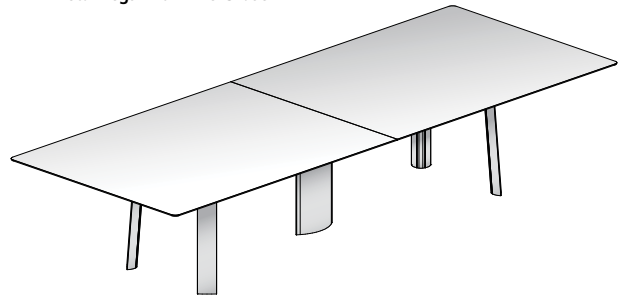

Wire Chase

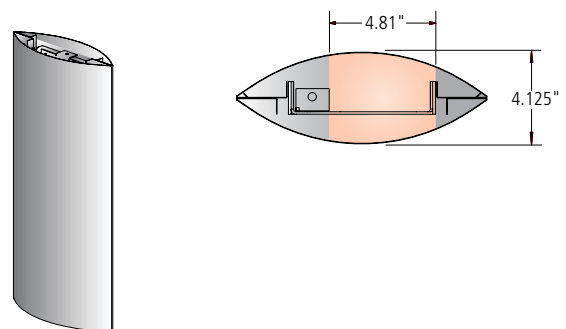

TABLE TOP POWER OPTION: POWER MATRIX

Power Matrix is filled with a broad array of high performance features and refined aesthetic elements.

POWER

Power Matrix features two simplex receptacles for power connectivity. An optional USB-A+C charger can also be specified in place of one of the simplex receptacles when desired. Corded or hardwired in-feed options add flexibility.

DATA/AV FACEPLATES

Power Matrix accommodates Modular AV Inserts/Plates for unparalleled flexibility in data and AV connectivity.

DESIGN

Power Matrix units feature a clear anodized aluminum body and a bezel, available in powder coat, polished chrome or clear anodized finish options.

PERFORMANCE

Friction hinges ensure smooth travel through the door's range of motion and can hold the door in any position. Hidden door stops maintain the minimalist aesthetic. Cable storage is both concealed and ample.

DOORS

Power Matrix is offered in multiple door material options, including metal, glass and grain-matched wood cut from the same table top.

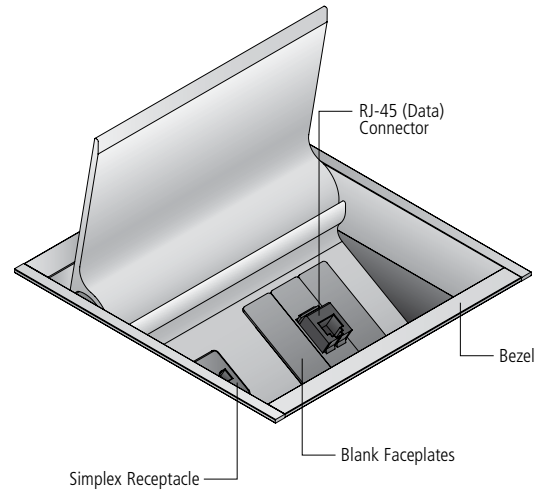

TABLE TOP POWER OPTION: POWER MATRIX

STANDARD CONFIGURATION

Power Matrix is offered with a pre-determined quantity of simplex outlets and AV faceplates. An optional 2 amp USB-A+C charger (1 amp per port) replaces one of the simplex outlets.

Small

- Single door design
- 5.375" x 6" cutout
- Two simplex outlets
- Three AV faceplates. Standard configuration includes two blank faceplates and one faceplate with two RJ-45 (data) connectors.
- (1) 12' plug-in infeed cord

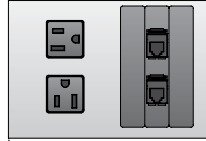

DIMENSIONS

The small Power Matrix unit includes a low-profile pan beneath the work surface to conceal the unit and provide ample storage capacity for excess cables.

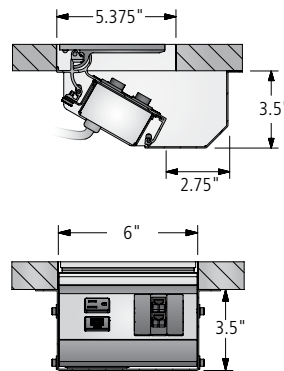

FIELD-WIRED

Some local electrical codes may require field-wiring during installation. In such instances, a Field-Wired option may be specified. In this configuration, each Power Matrix unit will be supplied with a 6' flexible metal conduit with hot, ground and neutral wires.

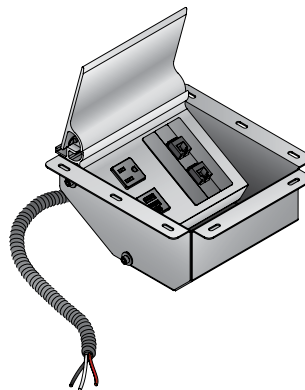



TABLE TOP POWER OPTION: POWER MATRIX

LOCATION CODES

Power Matrix is offered in a variety of locations and quantities per table size, offering a broad range of performance and pricing options.

POWER MATRIX SMALL	LOCATION	QUANTITY OF UNITS TO ORDER
PS-1	One at center	1
PS-2	One at each end	2
PS-3	One at center and one at each end	3
PS-4	Four equally spaced	4

DOOR MATERIAL AND LOCATION AVAILABILITY BY TABLE SIZE

W = Wood Door G = Glass Door M = Metal Door

Length	Top Sections	Power Matrix Small			
		PS-1	PS-2	PS-3	PS-4
84	1	W/G/M	W/G/M	-	-
96	1	W/G/M	W/G/M	-	-
108	1	W/G/M	W/G/M	-	-
108	2	-	W/G/M	-	-
120	1	W/G/M	W/G/M	-	-
120	2	-	W/G/M	-	-
132	2	-	W/G/M	-	-
144	2	-	W/G/M	-	-
156	2	-	W/G/M	-	-
168	2	-	W/G/M	-	W/G/M
180	2	-	W/G/M	-	W/G/M
192	2	-	W/G/M	-	W/G/M
192	4	-	W/G/M	-	W/G/M
204	2	-	W/G/M	-	W/G/M
204	4	-	W/G/M	-	W/G/M
216	2	-	W/G/M	-	W/G/M
216	4	-	W/G/M	-	W/G/M
228	2	-	W/G/M	-	W/G/M
228	4	-	W/G/M	-	W/G/M
240	2	-	W/G/M	-	W/G/M
240	4	-	W/G/M	-	W/G/M

TABLE TOP POWER OPTION: POWER MATRIX

POWER MATRIX SMALL LOCATION OPTIONS

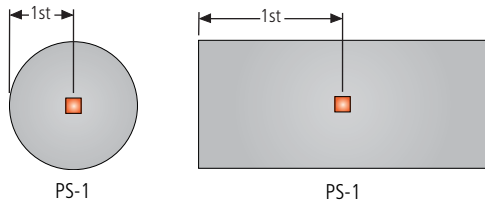

PS-1	
Length	Center of Power Matrix
84	42
96	48
108	54
120	60

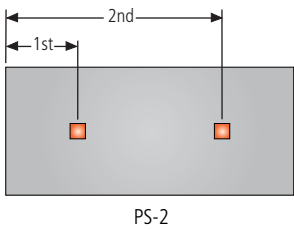

PS-2		
Length	Center of 1st Power Matrix	Center of 2nd Power Matrix
84	32.5	51.5
96	32.5	63.5
108	32.5	75.5
120	32.5	87.5
132	32.5	99.5
144	32.5	111.5
156	32.5	123.5
168	32.5	135.5
180	32.5	147.5
192	32.5	159.5
204	32.5	171.5
216	32.5	183.5
228	32.5	195.5
240	32.5	207.5

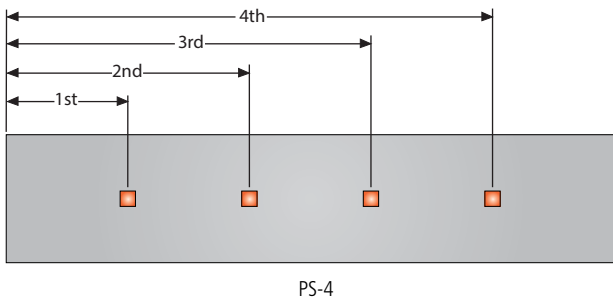

PS-4				
Length	Center of 1st Power Matrix	Center of 2nd Power Matrix	Center of 3rd Power Matrix	Center of 4th Power Matrix
168	32.5	66.833	101.167	135.5
180	32.5	70.833	109.167	147.5
192	32.5	74.833	117.167	159.5
204	32.5	78.833	125.167	171.5
216	32.5	82.833	133.167	183.5
228	32.5	86.833	141.167	195.5
240	32.5	90.633	149.167	207.5



UNDER SURFACE POWER OPTION: POWER RAIL

This low-profile option addresses the need for power & data connectivity just below the table top. This is an ideal choice for those who desire a visually uninterrupted table top and appreciate the inherent flexibility of the Power Rail to be removed at a later date as they transition to a truly wireless environment.



Power Rails are available in three configurations:

- Two simplex receptacles (UL Listed)
- One simplex receptacle and one powered USB-A+C connector (UL Listed)
- Two single space A/V faceplate designed for use with Modular AV Inserts/Plates

Held in place with thumb screws, Power Rail units can be placed anywhere along the perimeter of the table. This flexible mounting design allows for additional units to be added as necessary, or to be removed when no longer needed.

When Power Rails are specified on a Kai table, a direct plug-in infeed or hardwired option is available. The direct plug-in infeed option has a single circuit electrical system and the hardwire option requires a two-circuit electrical system. Maximum of 12 Power Rails per table.

Front Elevation



Side Elevation

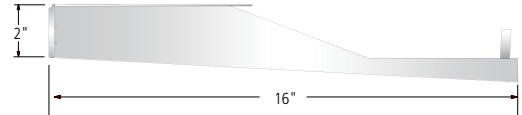

TABLE LENGTH	84	96	108	120	132	144	156	168	180	192	204	216	228	240
RECTANGLE														
Total maximum combined number of power and data rails that can fit onto the table	12	14	16	18	20	22	24	26	28	30	32	34	36	38
Total maximum number of power rails that can go on a table	8	8	8	8	8	8	12	12	12	12	12	12	12	12



FREESTANDING POWER OPTION: TECH ZONE

TECH ZONE

Simple, easy to use and portable, this freestanding table top power option allows you to easily charge all of your devices.

Available in two configurations with a variety of power and data connectivity options. Includes a 72"-long plug-in infeed cord.

ZONE-USB-C

Includes two simplex receptacles, one data port and one charging USB-A+C charging port

ZONE-DATA

Includes two simplex receptacles and two open data ports

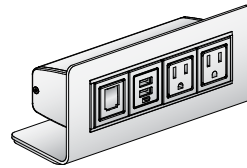

Tech Zone - Side View

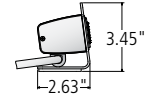

ZONE-USB-C



ZONE-DATA





BASE LOCATIONS

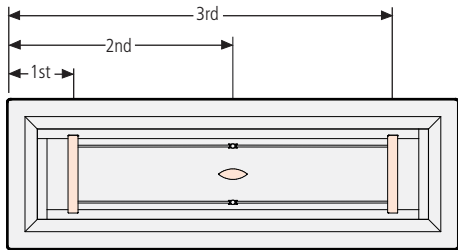

RECTANGLE PANEL BASE			
Table Size	Center of 1st Base	Center of 2nd Base	Center of 3rd Base
84 x 48	26.5	-	57.5
84 x 54	26.5	-	57.5
96 x 48	26.5	-	69.5
96 x 54	26.5	-	69.5
108 x 48	26.5	-	81.5
108 x 54	26.5	-	81.5
120 x 48	26.5	-	93.5
120 x 54	26.5	-	93.5
120 x 60	26.5	-	93.5
132 x 48	26.5	-	105.5
132 x 54	26.5	-	105.5
132 x 60	26.5	-	105.5
144 x 48	26.5	-	117.5
144 x 54	26.5	-	117.5
144 x 60	26.5	-	117.5
156 x 48	26.5	-	129.5
156 x 54	26.5	-	129.5
156 x 60	26.5	-	129.5
168 x 48	26.5	-	141.5
168 x 54	26.5	-	141.5
168 x 60	26.5	-	141.5
180 x 60	26.5	90	153.5
180 x 60	26.5	90	153.5
180 x 60	26.5	90	153.5
192 x 48	26.5	96	165.5
192 x 54	26.5	96	165.5
192 x 60	26.5	96	165.5
204 x 48	26.5	102	177.5
204 x 54	26.5	102	177.5
204 x 60	26.5	102	177.5
216 x 54	26.5	108	189.5
216 x 60	26.5	108	189.5
228 x 54	26.5	114	201.5
228 x 60	26.5	114	201.5
240 x 54	26.5	120	213.5
240 x 60	26.5	120	213.5



BASE LOCATIONS

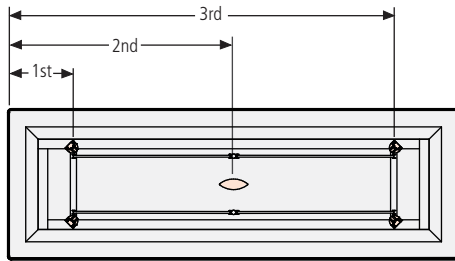

RECTANGLE METAL LEG

Table Size	Center of 1st Base	Center of 2nd Base	Center of 3rd Base
84 x 48	25.5	-	58.5
84 x 54	25.5	-	58.5
96 x 48	25.5	-	70.5
96 x 54	25.5	-	70.5
108 x 48	25.5	-	82.5
108 x 54	25.5	-	82.5
120 x 48	25.5	-	94.5
120 x 54	25.5	-	94.5
120 x 60	25.5	-	94.5
132 x 48	25.5	-	106.5
132 x 54	25.5	-	106.5
132 x 60	25.5	-	106.5
144 x 48	25.5	-	118.5
144 x 54	25.5	-	118.5
144 x 60	25.5	-	118.5
156 x 48	25.5	-	130.5
156 x 54	25.5	-	130.5
156 x 60	25.5	-	130.5
168 x 48	25.5	-	142.5
168 x 54	25.5	-	142.5
168 x 60	25.5	-	142.5
180 x 60	25.5	90	154.5
180 x 60	25.5	90	154.5
180 x 60	25.5	90	154.5
192 x 48	25.5	96	166.5
192 x 54	25.5	96	166.5
192 x 60	25.5	96	166.5
204 x 48	25.5	102	178.5
204 x 54	25.5	102	178.5
204 x 60	25.5	102	178.5
216 x 54	25.5	108	190.5
216 x 60	25.5	108	190.5
228 x 54	25.5	114	202.5
228 x 60	25.5	114	202.5
240 x 54	25.5	120	214.5
240 x 60	26.5	120	213.5



VENEER TOP



RECTANGLE TOP

BASE KEY

- V-MB Metal Legs
- V-PR Metal Rectangle Base

RECTANGLE TABLES

MODEL #	L x W	BASES	TOP SECTIONS	SEATING CAPACITY	-V-MB	-V-PR
KATT-8448	84 x 48	2	1	8	20,887	20,887
KATT-8454	84 x 54	2	1	10	22,360	22,360
KATT-9648	96 x 48	2	1	8	22,570	22,570
KATT-9654	96 x 54	2	1	10	24,254	24,254
KATT-10848	108 x 48	2	1	10	24,254	24,254
KATT-10854	108 x 54	2	1	12	26,148	26,148
KATT-12048	120 x 48	2	1	10	25,937	25,937
KATT-12054	120 x 54	2	1	12	28,042	28,042
KATT-12060	120 x 60	2	1	12	30,146	30,146
KATT-13248	132 x 48	2	2	10	27,621	27,621
KATT-13254	132 x 54	2	2	12	29,936	29,936
KATT-13260	132 x 60	2	2	12	32,251	32,251
KATT-14448	144 x 48	2	2	12	29,305	29,305
KATT-14454	144 x 54	2	2	14	31,830	31,830
KATT-14460	144 x 60	2	2	14	34,355	34,355
KATT-15648	156 x 48	2	2	12	30,988	30,988
KATT-15654	156 x 54	2	2	14	33,724	33,724
KATT-15660	156 x 60	2	2	14	36,460	36,460
KATT-16848	168 x 48	2	2	14	32,672	32,672
KATT-16854	168 x 54	2	2	16	35,618	35,618
KATT-16860	168 x 60	2	2	16	38,564	38,564
KATT-18048	180 x 48	3	2	14	37,500	37,500
KATT-18054	180 x 54	3	2	16	40,657	40,657
KATT-18060	180 x 60	3	2	16	43,814	43,814
KATT-19248	192 x 48	3	2	16	39,184	39,184
KATT-19254	192 x 54	3	2	18	42,551	42,551
KATT-19260	192 x 60	3	2	18	45,918	45,918
KATT-20448	204 x 48	3	2	16	40,868	40,868
KATT-20454	204 x 54	3	2	18	44,445	44,445
KATT-20460	204 x 60	3	2	18	48,023	48,023
KATT-21654	216 x 54	3	2	20	46,339	46,339
KATT-21660	216 x 60	3	2	20	50,127	50,127
KATT-22854	228 x 54	3	2	20	48,233	48,233
KATT-22860	228 x 60	3	2	20	52,232	52,232
KATT-24054	240 x 54	3	2	20	50,127	50,127
KATT-24060	240 x 60	3	2	20	54,336	54,336

OPTIONS	CODE	PRICE	NOTES
Power and Data Options			See pages 20-25
Polished Chrome Base Finish	Add -PCKL	Add \$2,876	
Polished Chrome Camber Rail Assembly:			
Table lengths 108"-144"	Add -PCKC1	Add \$1,224	Camber Rail Assembly not present on tables 96" and shorter
Table lengths 156"-192"	Add -PCKC2	Add \$1,561	
Table lengths 204"-240"	Add -PCKC3	Add \$1,902	
Multi-Section Tops:			
108" and 120" one-piece tops split into two sections	Specify -2		
204", 216", 228" and 240" two-piece tops split into three sections	Specify -3		



VENEER TOP

GENERAL INFORMATION

- Tops are 5/16"-thick aluminum
- Seating capacity based on 27" per person
- Overall table height 29.5"
- Table frame apron finish will match Base finish selection. Exception: If Base finish is Polished Chrome, frame apron will be Foil.
- If the Polished Chrome Camber Rail Assembly option is not selected, the Camber Rail assembly finish will match Base finish selection. Exceptions: If Base finish is Clear Anodized or Polished Chrome default, Camber Rail assembly finish will be Foil.
- Camber Rail assembly not present on tables 96" and shorter
- Tables longer than 168" include a center column. Center column finish will match Base finish selection. Exceptions: If Base finish is Clear Anodized or Polished Chrome, center column will be Foil.

REQUIRED INFORMATION (ORDER CANNOT BE ENTERED WITHOUT THIS INFORMATION)

See appendix page vi for surface material options.

- Choose Veneer Finish
- Choose Base Finish. Upcharge applies for Polished Chrome option (-PCKL).
Note: Clear Anodized and Polished Chrome options are only available on Metal Leg base

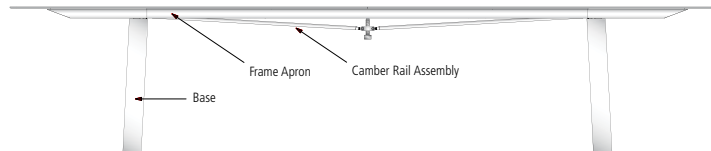



GLASS TOP



RECTANGLE TOP

BASE KEY

- MB Metal Legs
- PR Metal Rectangle Base

RECTANGLE TABLES

MODEL #	L x W	BASES	TOP SECTIONS	SEATING CAPACITY	-MB	-PR
KATT-8448-G	84 x 48	2	1	8	25,065	25,065
KATT-8454-G	84 x 54	2	1	10	26,832	26,832
KATT-9648-G	96 x 48	2	1	8	27,084	27,084
KATT-9654-G	96 x 54	2	1	10	29,105	29,105
KATT-10848-G	108 x 48	2	2	10	29,105	29,105
KATT-10854-G	108 x 54	2	2	12	31,378	31,378
KATT-12048-G	120 x 48	2	2	10	31,125	31,125
KATT-12054-G	120 x 54	2	2	12	33,651	33,651
KATT-12060-G	120 x 60	2	2	12	36,176	36,176
KATT-13248-G	132 x 48	2	2	10	33,146	33,146
KATT-13254-G	132 x 54	2	2	12	35,924	35,924
KATT-13260-G	132 x 60	2	2	12	38,702	38,702
KATT-14448-G	144 x 48	2	2	12	35,166	35,166
KATT-14454-G	144 x 54	2	2	14	38,196	38,196
KATT-14460-G	144 x 60	2	2	14	41,226	41,226
KATT-15648-G	156 x 48	2	2	12	37,186	37,186
KATT-15654-G	156 x 54	2	2	14	40,469	40,469
KATT-15660-G	156 x 60	2	2	14	43,752	43,752
KATT-16848-G	168 x 48	2	2	14	39,207	39,207
KATT-16854-G	168 x 54	2	2	16	42,742	42,742
KATT-16860-G	168 x 60	2	2	16	46,277	46,277
KATT-18048-G	180 x 48	3	2	14	45,000	45,000
KATT-18054-G	180 x 54	3	2	16	48,789	48,789
KATT-18060-G	180 x 60	3	2	16	52,577	52,577
KATT-19248-G	192 x 48	3	2	16	47,021	47,021
KATT-19254-G	192 x 54	3	2	18	51,062	51,062
KATT-19260-G	192 x 60	3	2	18	55,102	55,102
KATT-20448-G	204 x 48	3	3	16	49,042	49,042
KATT-20454-G	204 x 54	3	3	18	53,334	53,334
KATT-20460-G	204 x 60	3	3	18	57,628	57,628
KATT-21654-G	216 x 54	3	3	20	55,607	55,607
KATT-21660-G	216 x 60	3	3	20	60,153	60,153
KATT-22854-G	228 x 54	3	3	20	57,880	57,880
KATT-22860-G	228 x 60	3	3	20	62,679	62,679
KATT-24054-G	240 x 54	3	3	20	60,153	60,153
KATT-24060-G	240 x 60	3	3	20	65,204	65,204

OPTIONS	CODE	PRICE	NOTES
Power and Data Options			See pages 20-25
Polished Chrome Base Finish	Add -PCKL	Add \$2,876	
Polished Chrome Camber Rail Assembly:			
Table lengths 108"-144"	Add -PCKC1	Add \$1,224	Camber Rail Assembly not present on tables 96" and shorter
Table lengths 156"-192"	Add -PCKC2	Add \$1,561	
Table lengths 204"-240"	Add -PCKC3	Add \$1,902	
Satin Glass Options:			
84"-120" Tables	Add -KSG	\$1,112	
132"-180" Tables	Add -KSG	\$1,527	



GLASS TOP

GENERAL INFORMATION

- Glass tops are 3/8" thick back-painted, low-iron glass
- Seating capacity based on 27" per person
- Overall table height 29.5"
- Table frame apron finish will match Base finish selection. Exception: If Base finish is Polished Chrome, frame apron will be Foil.
- If the Polished Chrome Camber Rail Assembly option is not selected, the Camber Rail assembly finish will match Base finish selection.
Exceptions: If Base finish is Clear Anodized or Polished Chrome default, Camber Rail assembly finish will be Foil.
- Camber Rail assembly not present on tables 96" and shorter
- Tables longer than 168" include a center column. Center column finish will match Base finish selection.
Exceptions: If Base finish is Clear Anodized or Polished Chrome, center column will be Foil.
- Due to color variation inherent in the natural acid etching process, Satin Etched Glass is not available on tables longer than 180" or wider than 60"
- Glass sections noted are for tables without power units. When power units are specified in the table, the glass sections are determined by the size of the power unit, quantity and location.

REQUIRED INFORMATION (ORDER CANNOT BE ENTERED WITHOUT THIS INFORMATION)

See appendix page vi for surface material options.

- Choose Glass Finish (Satin Glass upcharges apply, see options above)
- Choose Base Finish. Upcharge applies for Polished Chrome option (-PCKL).
Note: Clear Anodized and Polished Chrome options are only available on Metal Leg base

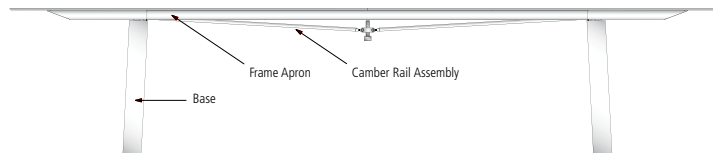

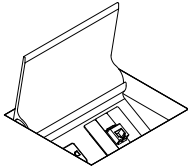

POWER AND DATA OPTIONS

POWER MATRIX SMALL	MODEL #	DESCRIPTION	W x D	SIMPLEX OUTLETS	BLANK	DATA*	PRICE
	PM-SM-G-B	Small - Glass Door	6 x 5.375	2	2	1	1,635
	PM-SM-M-B	Small - Glass Metal	6 x 5.375	2	2	1	1,635
	PM-SM-W-B	Small - Wood Door	6 x 5.375	2	2	1	2,062

*Each data faceplate includes two RJ-45 (Data) connectors

OPTIONS	CODE	PRICE	NOTES
4 Simplex Receptacles	Add -FOUR	No Charge	Replace Modular AV Inserts/Plates with 2 simplex receptacles
3 Simplex Receptacles/Charging USB-A+C	Add -THREE-C	No Charge	Replace Modular AV Inserts/Plates with 1 simplex receptacle and 1 charging USB-A+C
USB-A+C Charging	Add -USB-C	\$128 per unit	USB-A+C charger, replaces one of the simplex outlets
Polished Chrome Door	Add -PD	\$245 per unit	Only available with metal door option
Polished Chrome Bezel	Add -PB	\$349 per unit	Only available on glass, stone and laminate top tables
Field-Wired	Add -FW	Deduct \$48 per unit	May be required in New York City, Chicago and San Francisco. Check with an electrician for local codes and requirements.
Single Infeed Option Available	See page 22		

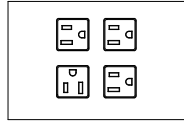

-FOUR

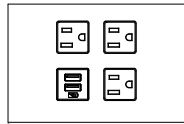

-THREE-C

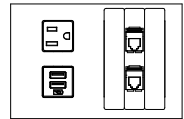

-USB-C

GENERAL INFORMATION

- Wood species and finish will default to the same as the table top if wood door version is specified
- Glass & wood doors are 1/4"-thick, metal doors are 1/8"-thick
- Glass door is back painted low-iron glass
- Interior body is clear anodized aluminum
- Each unit includes a 15 amp, 12' power infeed (plug in only)
- If Field-Wired option is specified, each unit includes a 6' flexible metal conduit and requires a hardwire connection
- Standard configuration: Two simplex receptacles, two RJ-45 data connectors and two single blank faceplates
- Metal Bezel included with all door material options
- Additional data/AV faceplate options are on page 24

REQUIRED INFORMATION: (ORDER CANNOT BE ENTERED WITHOUT THIS INFORMATION)

- See appendix page vi for surface material options.
- Choose location code & quantity from the chart on page 21
 - Choose Glass Door Finish, if glass door version is specified
 - Choose Metal Finish, bezel included with all door material options



POWER AND DATA OPTIONS

LOCATION CODES	POWER MATRIX SMALL	LOCATION	QUANTITY OF UNITS TO ORDER
PS-1		One at center	1
PS-2		One at each end	2
PS-3		One at center and one at each end	3
PS-4		Four equally spaced	4

DOOR MATERIAL AND LOCATION AVAILABILITY BY TABLE SIZE

W = Wood Door G = Glass Door M = Metal Door

Length	Top Sections	Power Matrix Small			
		PS-1	PS-2	PS-3	PS-4
84	1	W/G/M	W/G/M	-	-
96	1	W/G/M	W/G/M	-	-
108	1	W/G/M	W/G/M	-	-
108	2	-	W/G/M	-	-
120	1	W/G/M	W/G/M	-	-
120	2	-	W/G/M	-	-
132	2	-	W/G/M	-	-
144	2	-	W/G/M	-	-
156	2	-	W/G/M	-	-
168	2	-	W/G/M	-	W/G/M
180	2	-	W/G/M	-	W/G/M
192	2	-	W/G/M	-	W/G/M
192	4	-	W/G/M	-	W/G/M
204	2	-	W/G/M	-	W/G/M
204	4	-	W/G/M	-	W/G/M
216	2	-	W/G/M	-	W/G/M
216	4	-	W/G/M	-	W/G/M
228	2	-	W/G/M	-	W/G/M
228	4	-	W/G/M	-	W/G/M
240	2	-	W/G/M	-	W/G/M
240	4	-	W/G/M	-	W/G/M



POWER AND DATA OPTIONS

SINGLE INFEED OPTION	MODEL #	DESCRIPTION	PRICE
	SI-H	Single In-Feed Option, Hard-wired	608
	SI-C	Single In-Feed Option, Corded (Plug-in)	734

GENERAL INFORMATION

- Tables 72" -120" in length include 2 duplex receptacles with the modular power system
- Tables 132"-240" in length include 3 duplex receptacles with the modular power system
- Hardwired and Corded Single In-Feed options are 7' long
- Single In-Feed option cannot be specified in conjunction with the Field-Wired (-FW) option

HARDWIRE INFEED POWER RAIL KIT	MODEL #	TOTAL # OF RAILS	ELECTRICAL OUTLETS	(2) SIMPLEX -S2	ELECTRICAL OUTLETS	(1) SIMPLEX / (1) CHARGING USB -S3
(Includes Power Rails, Hardwire Infeed and Modular Power Components)	KA-RAIL-1-H	1	2	1,462	1	1,462
	KA-RAIL-2-H	2	4	2,320	2	2,320
	KA-RAIL-3-H	3	6	3,177	3	3,177
	KA-RAIL-4-H	4	8	4,036	4	4,036
	KA-RAIL-5-H	5	10	4,894	5	4,894
	KA-RAIL-6-H	6	12	5,749	6	5,749
	KA-RAIL-7-H	7	14	6,605	7	6,605
	KA-RAIL-8-H	8	16	7,461	8	7,461
	KA-RAIL-9-H	9	18	8,321	9	8,321
	KA-RAIL-10-H	10	20	9,179	10	9,179
	KA-RAIL-11-H	11	22	10,035	11	10,035
	KA-RAIL-12-H	12	24	10,892	12	10,892

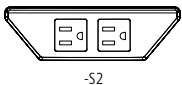

-S2

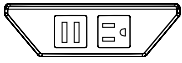

-S3

GENERAL INFORMATION

- Includes modular power electrical system
- Hardwire infeed is 7' long
- Simplex receptacles will be white, when Burnished, Cloud or Foil powdercoat finishes are specified. Black simplex receptacles will be used for all other powdercoat finishes.
- Power Rails not available in Clear or Black Anodized

REQUIRED INFORMATION: (ORDER CANNOT BE ENTERED WITHOUT THIS INFORMATION)

See appendix page vi for surface material options.

- Choose Metal Finish



POWER AND DATA OPTIONS

CORDED INFEED POWER RAIL KIT	MODEL #	TOTAL # OF RAILS	ELECTRICAL OUTLETS	(2) SIMPLEX -S2	ELECTRICAL OUTLETS	(1) SIMPLEX / (1) CHARGING USB -S3
(Includes Power Rails, Corded Infeed and Modular Power Components)	KA-RAIL-1-C	1	2	1,589	1	1,589
	KA-RAIL-2-C	2	4	2,450	2	2,450
	KA-RAIL-3-C	3	6	3,306	3	3,306
	KA-RAIL-4-C	4	8	4,161	4	4,161
	KA-RAIL-5-C	5	10	5,018	5	5,018
	KA-RAIL-6-C	6	12	5,879	6	5,879
	KA-RAIL-7-C	7	14	6,736	7	6,736
	KA-RAIL-8-C	8	16	7,591	8	7,591
	KA-RAIL-9-C	9	18	8,448	9	8,448
	KA-RAIL-10-C	10	20	9,307	10	9,307
	KA-RAIL-11-C	11	22	10,165	11	10,165
	KA-RAIL-12-C	12	24	11,021	12	11,021

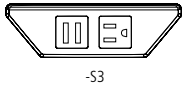
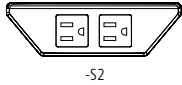

GENERAL INFORMATION

- Includes modular power electrical system
- Corded single infeed is 7' long
- Corded Single Infeed option will require a 20amp outlet in the floor monument and reduces the modular electrical system in the table to a single circuit
- Simplex receptacles will be white, when Burnished, Cloud or Foil powdercoat finishes are specified. Black simplex receptacles will be used for all other powdercoat finishes.
- Power Rails not available in Clear or Black Anodized

REQUIRED INFORMATION: (ORDER CANNOT BE ENTERED WITHOUT THIS INFORMATION)

- See appendix page vi for surface material options.
- Choose Metal Finish

DATA RAIL	MODEL #	DESCRIPTION	PRICE
	KA-RAIL-DATA	Data Rail includes (1) blank faceplate and (1) dual RJ-45 faceplate	664

KA-RAIL-DATA

GENERAL INFORMATION

- Data Rails not available in Clear or Black Anodized

REQUIRED INFORMATION: (ORDER CANNOT BE ENTERED WITHOUT THIS INFORMATION)

- See appendix page vi for surface material options.
- Choose Metal Finish

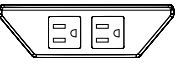
FIELD-WIRED	MODEL #	DESCRIPTION	(2) SIMPLEX -S2	(1) SIMPLEX / (1) CHARGING USB -S3
	KA-RAIL-FW	Field-Wired Power Rail	764	764

-S2

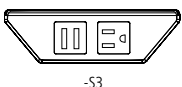

-S3

GENERAL INFORMATION

- Includes 6' flexible metal conduit and required a hardwire connection
- May be required in New York City, Chicago and San Francisco. Check with an electrician for local codes and requirements. A junction box will be provided when ordering the TW-RAIL-FW option.
- Power Rails not available in Clear or Black Anodized

REQUIRED INFORMATION: (ORDER CANNOT BE ENTERED WITHOUT THIS INFORMATION)

- See appendix page vi for surface material options.
- Choose Metal Finish



POWER AND DATA OPTIONS

INDIVIDUAL POWER RAIL	MODEL #	DESCRIPTION	(2) SIMPLEX -S2	(1) SIMPLEX / (1) CHARGING USB -S3
-----------------------	---------	-------------	--------------------	---------------------------------------

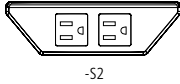

-S2

KA-RAIL	Power Rail	861	861
---------	------------	-----	-----

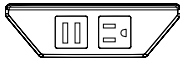

-S3

GENERAL INFORMATION

- Individual power rails do not include a modular power system. Each Power Rail must directly plug into a floor core with a 6'-cabled 15-amp plug-in infeed. (Typically used with smaller tables, rounds, squares, soft squares, where a modular power system is not required.)
- Simplex receptacles will be white, when Burnished, Cloud or Foil powdercoat finishes are specified. Black simplex receptacles will be used for all other powdercoat finishes.
- Power Rails not available in Clear or Black Anodized

REQUIRED INFORMATION: (ORDER CANNOT BE ENTERED WITHOUT THIS INFORMATION)

See appendix page vi for surface material options.

- Choose Metal Finish

GROMMET	MODEL #	DESCRIPTION	DIAMETER	PRICE
---------	---------	-------------	----------	-------



GR	Round Grommet	2" Dia	242
----	---------------	--------	-----

OPTIONS	CODE	PRICE	NOTES
---------	------	-------	-------

Polished Chrome Grommet	Add -PCG	\$98 per unit	
-------------------------	-----------------	---------------	--

GENERAL INFORMATION

- Available at center location only

REQUIRED INFORMATION: (ORDER CANNOT BE ENTERED WITHOUT THIS INFORMATION)

See appendix page vi for surface material options.

- Choose Metal Finish: Powder Coat, Clear Anodized or Polished Chrome (upcharge applies)

DATA FACEPLATES	MODEL #	DESCRIPTION	STYLE	W x H	PRICE
FLDF-1	Blank faceplate, single height	Single	3-1/2 x 5/8	81	
FLDF-2	One VGA 15-pin HD Female to Female Gender Changer, one 3.5mm Stereo Mini Jack to Solder Tabs	Single	3-1/2 x 5/8	284	
FLDF-3	One VGA 15-pin HD Female to Female Gender Changer	Single	3-1/2 x 5/8	223	
FLDF-4	One RJ-11 Female to Punch Down - Phone	Single	3-1/2 x 5/8	223	
FLDF-5	One RJ-45 Female to Female Barrel - Data	Single	3-1/2 x 5/8	182	
FLDF-6	Two RJ-45 Female to Female Barrels, single height	Single	3-1/2 x 5/8	244	
FLDF-7	Two RJ-45 Female to Punch Down for CAT 6 - AMP	Single	3-1/2 x 5/8	345	
FLDF-8	Two RJ-45 Female to Punch Down for CAT 6 - Leviton	Single	3-1/2 x 5/8	345	
FLDF-10	Two RJ-45 Female to Punch Down for CAT 6 - Panduit	Single	3-1/2 x 5/8	345	
FLDF-11	Two USB A Female to Two USB A Female on 10" Pigtails	Single	3-1/2 x 5/8	386	
FLDF-12	Blank faceplate, double height	Double	3-1/2 x 1-3/8	101	
FLDF-13	Two RJ-45 Female to Female Barrels, double height	Double	3-1/2 x 1-3/8	244	
FLDF-14	Cable Pass-Through Set - one top, one bottom	Double	3-1/2 x 1-3/8	426	
FLDF-15	One HDMI Female to Female Barrel	Single	3-1/2 x 5/8	284	

GENERAL INFORMATION

- Each KA-RAIL-DATA unit holds two single space faceplates
- Faceplates are black



POWER AND DATA OPTIONS

METAL WIRE CHASE COLUMN	MODEL #	W x D	PRICE
	KA-WC	11-1/2 x 4-1/4	967



GENERAL INFORMATION

- Can be located anywhere along the centerline of the table to cover a floor monument
- Metal shroud
- Includes a removable shroud panel to access the interior cavity for routing cables from the floor to the table

REQUIRED INFORMATION: (ORDER CANNOT BE ENTERED WITHOUT THIS INFORMATION)
 See appendix page vi for surface material options.
 ▪ Choose Metal Finish. Not available in Clear Anodized or Polished Chrome.

TECH ZONE	MODEL #	DESCRIPTION	SIMPLEX OUTLETS	OPEN DATA PORTS	CHARGING USB-A+C	PRICE
	ZONE-DATA	(2) Simplex receptacles, (2) Open data ports	2	2	-	375
	ZONE-USB-C	(2) Simplex receptacles, (1) Charging USB-A+C, (1) Open data port	2	1	1	449

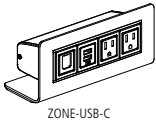

ZONE-USB-C

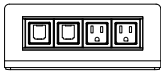

ZONE-DATA



ZONE-USB-C

GENERAL INFORMATION

- 72" long plug-in infeed cord
- Finish is black
- Includes a Voice/Data Adapter Kit to accept couplers and jacks when required



Appendix



This price book supercedes all previous versions.

Before placing your order, confirm you have all required information necessary. Lead times for orders begin after all required information is included and correct.

Delivery Information

We know lead times are important and sticking to them even more so. We work to maintain a 6-8 week lead time on all standard products in this book from receipt of a clean order. All orders are acknowledged with an approximate shipping date and will be invoiced with the price in effect at the date the purchase order is received. For current lead times, please review www.nucraft.com/resources/lead-times.

Shipping charges are prepaid (within the continental U.S.). Therefore, pricing is a delivered price based on normal ground transportation. If you have special instructions, need to ship by air, or are shipping to Alaska or Hawaii, contact Nucraft Customer Service. Nucraft can also help arrange to have products blanket wrapped for an additional charge. Contact the Nucraft Customer Service team or specify it on your purchase order.

Minimum Freight Charge: Any order below \$3,000 net will be assessed a \$500 net minimum freight charge (one per order).

Orders are subject to acquiring the materials required for manufacturing. Fulfillment can be affected by strikes, fires, embargoes and acts of government. These elements are beyond our control.

Nucraft offers a variety of services to accommodate a wide range of delivery requirements. Availability of these services is dependent on a number of factors and may not be offered with all shipments. Examples of delivery services that have additional fees include:

- Specific date
- Specific time of day, morning or afternoon
- Delivery to a warehouse before delivery to its final destination (unless product is picked up at the warehouse)

Contact the Nucraft Customer Service team for availability and pricing on these services.

Freight Terms

Shipping charges for Nucraft products are prepaid for standard delivery in the continental United States. Standard delivery is defined as follows: Product is delivered on a 53' trailer being pulled by a long-haul tractor (total length of 85'). Facility will receive delivery Monday through Friday between the hours of 8:00 AM and 4:00 PM. Facility has docks with levelers and a fork truck for unloading. Product will be loaded on load bars two levels high. Receiving facility is responsible to have personnel on hand to unload the truck upon arrival, drivers do not unload. Delivery sites or times that do not meet these criteria may be accommodated, but will incur a charge to cover additional shipping costs. Please **notify Nucraft a minimum of two weeks prior to shipment** to arrange special services and determine additional charges.

Storage

Nucraft has no storage facilities for finished product. If a customer cannot accept an order when it is ready for shipment, the customer must designate an alternative shipping address. If no address is provided, Nucraft may, at its discretion, transfer the product to storage. If product is transferred to an off-site storage facility, the customer may be charged for transportation to the facility and for any associated storage fees. Nucraft considers transfer of the product to a storage facility the equivalent of shipment, including invoicing and payment. Customers assume the risk of damage or loss during storage.

Transportation Times and Delays

Third party carriers that Nucraft contracts with will make reasonable efforts to accommodate requested delivery times and dates. Scheduled delivery appointments may, however, be delayed for a variety of reasons, including inclement weather, traffic, transportation equipment problems, and delays encountered at other delivery locations along the delivery route. Nucraft does not recommend scheduling activities that depend on the delivery appointment (for example, scheduling furniture installers to install furniture the day of the delivery appointment). Nucraft shall not be liable for any costs incurred as a result of a missed delivery appointment.

Shipment Damage Claims

Legal title to merchandise passes to the buyer upon acceptance by the carrier. Inspect all cartons upon delivery. Details of visible damage should be noted on the delivery receipt. Do not destroy packaging, transport to site, or install product if damage is found upon inspection. Inspection of products should be completed upon delivery to the receiver. If visible damage is apparent, a claim should be filed immediately with Nucraft Customer Service. If visible damage is not apparent, sign the delivery receipt "No visible damage." This will allow recourse for a concealed damage claim. Concealed damage claims must be filed within 15 days of receipt, **prior to transporting or installing any product.**

Do not destroy packing materials until shipment has been inspected. If damage is found, proceed to file a claim with Nucraft Customer Service.

Failure to make any claims against Nucraft within 15 days shall constitute acceptance of the merchandise and a waiver of any defects, errors or shortages discovered upon inspection.

Cancellations

Cancellations must be reviewed by our Customer Service team. Because we build your products to order, orders cannot be cancelled once processing has begun. Processing includes but is not limited to development of shop drawings and other engineering drawings. If cancellation is approved, a processing fee of 20-100% will be assessed based on the status of the order.

Change Order Policy

Nucraft will make every attempt to honor any reasonable change request to product provided that the request is received prior to start of production. Change orders will be accepted only if the request is made in writing and received in time to make the change. Nucraft reserves the right to increase our acknowledged price and ship date if necessary to make the requested changes. Please submit any change order request to our Customer Service team. Nucraft will assess charges to the customer as stipulated in the following:

- Standard Orders: Change orders received prior to production will be charged \$400 net to cover administrative costs.
- Special Orders: Change orders received prior to production will be charged \$400 net to cover administrative costs. There may be additional costs associated with engineering labor required for the change order.
- Change orders received after production must be evaluated by Nucraft. If approved, the charge will be \$400 net plus any restocking charges accumulated. There may be additional costs associated with engineering and/or manufacturing labor, as well as material costs, required for the change order.



Repair Authorization

Prior written approval is required for repairs of merchandise charged to Nucraft. Failure to do so will result in customer funded repairs.

Payment Terms

Deposits are required at the time of order due to the custom nature of our products. See information regarding Cancellations above.

Credit terms are available to qualified customers. Please contact AR@Nucraft.com to start the application process. Note that the credit application process requires a valid sales tax exemption or resale tax certificate, Form W-9, and three current trade references.

Credit Card Payments are accepted via web portal. Please contact AR@Nucraft.com for payment instructions. Note that a 2% convenience fee will be added for using this payment method and no early pay discounts are allowed on credit card payments.

Warranty

Nucraft Furniture is warranted to be free from defects in materials and workmanship for a period of ten years of single shift use. Limitations include:

- Mechanical Devices such as latches, casters, and other moving components are warranted for five years of the date of original delivery.
- Height adjustable components are warranted for two years of the date of original delivery.
- The following are warranted for one year of the date of original delivery:
 - Textiles
 - Electrical Components
 - Refrigeration Units
 - Custom Products not described in Nucraft's Catalogue

This warranty is applicable only if furniture is properly installed and maintained in an office environment. This warranty extends only to products manufactured and sold in North America and only to original purchasers acquiring new Nucraft product through authorized dealers or approved sellers.

During this warranty period, Nucraft's sole obligation is to repair or replace, at Nucraft's discretion, products which prove to be defective during the warranty period.

This warranty does not cover:

- Damage caused by a carrier.
- Damage from user modification, misuse, abuse, accident, or negligence.
- Customer's Own Material (COM) specified by the customer that is not a standard product offering.
- Color, grain, or texture of wood and other covering material.

Nucraft extends no other warranties, expressed or implied, including warranty of merchantability or fitness for a particular purpose. Nucraft shall not be liable for loss of time, inconvenience, commercial loss, incidental or consequential damages.

Environmental Statement

Nucraft is committed to supporting responsible environmental policies and practices in all that we do. We strive for sustainability, weighing our business decisions against the costs to the ecological, social and economic systems they affect.

Our products are manufactured to meet the credit requirements of the U.S. Green Building Council's LEED rating systems in one or more of the following categories:

- Recycled Content
- Certified Wood
- Low-Emitting Materials

Computer Aided Planning

Nucraft products and pricing are available via CET and 2020 Worksheet, an AutoCAD®-based space planning tool.

2020 Worksheet is an integrated software system developed specifically for interior designers and facility planners to enhance workplace performance. This modern suite of applications works together seamlessly, in concert. Navigate catalogs, select products, design in plan view and 3D, assign options, create worksheets and build a project where you want, when you want. Take your pick. It's dynamic and interactive. Design projects are a work in progress. And now you can perform any of the many discrete tasks that go into a project any time, any place.

Product symbols (Revit, 2D and 3D) are available on the Nucraft website at www.nucraft.com/resources/designer-tools/product-symbols.

iSpec®

Nucraft offers a free online product configuration and specification service that saves you time and allows you to be creative while leaving the nuts and bolts to someone else. No specific software is required, nor is there any learning curve. This service applies to all Nucraft products. For additional information, visit www.nucraft.com/resources/designer-tools/ispec.



Surface Materials Palette

We crafted our materials palette using the same demanding standards that distinguish our furniture. Thoughtful design and attention to every detail elevate your possibilities.

Anchored by Nucraft veneers, unrivaled for clarity, quality, and depth of finish, our collection of surface materials comprises a sophisticated set of balanced elements that supports your design vision.

Some elements have their roots in Nucraft's rich heritage. Others are new materials and reflect current trends and taste. Together, they ensure that you're ready for today and positioned well for the future. Beautifully.

Custom Finishes

Nucraft specializes in expert custom finish matching. For a nominal upcharge we can provide custom finishes, and we are frequently asked to match the finishes of other furniture manufacturers. For finishes that appear unusual to match or for customers directly requesting a sample, a finish sample will be sent for approval prior to entering the order.

Custom finishes requiring colored varnishes to create a painted look can only be applied to Maple veneer and require one extra week in addition to the standard lead time. Nucraft's standard black finish (G82) can be applied to all Nucraft standard veneers. Walnut is the standard black veneer. Other species must be specified when ordering.

Clear coat on a special veneer requires an approved sample.

Custom finishes carry a 10% upcharge per item, per finish, capped at \$2,200 List.

Custom finish upcharges are not applied to any item that is not wood. Example: casters, ganging connectors, power options..

Treatments

Note: Default veneer sheen will vary per finish and product. Default finish is bolded on pages vi-vii. If no direction is provided on incoming orders, default sheen will be selected. In addition, default veneer cut is noted in the price list. If no direction is provided on incoming orders, default cut will be selected.

Gloss: Gloss is a durable finish that tends to nicely mask normal wear and leaves wood grain visible to the eye. It achieves a medium gloss open pore appearance (40 – 50 sheen range). Finish numbers preceded by the letter "G" indicate a Gloss finish.

Matte: Like Gloss, Matte is durable, tends to nicely mask normal wear and leaves wood grain visible to the eye. It achieves a low luster, open pore appearance (10 – 20 sheen range). Finish numbers preceded by the letter "M" indicate a Matte finish.

Since each veneer type responds differently to both types of treatment, all will have a distinctive look and feel when finished. For example, a Walnut veneer with a Gloss treatment will remain much more textured than a Cherry veneer with the same treatment.

About the Wood

All Nucraft veneers are carefully selected for uniformity of color and grain. Still, wood is a natural substance and minor variations may occur due to its own uniqueness. Because of this, the furniture you receive may not be an exact match to our samples.

Nucraft takes great pride in our finish color consistency. However, wood is a natural product that will have color variation within a single piece of furniture, as well as from one piece to the next. Other factors also affect color over time, such as exposure to light (both intensity and duration). For example, lighter finishes cause more variation in colors over time.

In cases where a returning customer wants a precise match with existing furniture, we recommend sending a sample of the existing furniture finish. Please contact Nucraft Customer Service to determine an appropriate sample. This will ensure a finish match between old and new orders. This type of order is considered a control sample. There will be a 10% upcharge on an order of this type. Due to natural aging of veneers, natural finishes may vary.

Care and Maintenance of Wood Finishes

Our finish material is a crystal clear, urethane acrylic blend. This type of finish may be repaired in the field by a qualified refinisher.

Nucraft recommends using a damp cloth to clean your fine wood furniture. Always wipe with the grain of the wood. Should your wood furniture require a more thorough cleaning, we recommend using a mild cleaner such as Joy dish soap or Murphy's oil soap, thoroughly diluted in water (one part soap to thirty parts water). Water will not damage Nucraft's finish, but it may leave surface spots when it dries. To avoid this, dry the surface with a soft cloth after it is cleaned. Marks that cannot be removed with the cleaning methods above may be able to be removed using naphtha, a mild degreasing solvent.

Caution: while the use of polishes that contain wax, petroleum solvents or silicones may immediately enhance the "shine" of a product, it may also eventually remove the fine original finish applied in our factory. Silicone on the surface of wood may also make it very difficult to respray or refinish.

All Nucraft furniture is inspected and polished before it leaves our factory. In some instances, the packing materials may imprint on the factory polish. Cleaning and polishing the furniture once it is unpacked will normally restore the furniture to its original beauty.

In some cases, the rubber support feet used on the bottom of common office equipment (teleconferencing phones, laptops, microphones, copiers, etc.) can create unsightly marks in the surface of wood tops, due to oxidation of the lacquer finish. We suggest these machines be placed on a protective type of padding, such as felt.

Wood will fade as a result of exposure to UV light. This is particularly prevalent with light finishes. If color changes due to fading are a concern for your application, the impact can be minimized by selecting medium to dark stains for your wood surfaces. Our top coat includes a UV inhibitor which makes the finishes less prone to fading.



Laminates

Selected Formica®, Nevamar®, and Wilsonart® laminates are available on Training Tables, Conference Tables, Conference Room Furniture and select Occasional Tables. For standard laminate and wood pricing, refer to individual item pricing columns. It is important to note that wood grain laminates are unable to be grain matched over multi-piece table top applications.

Non-Standard Laminates and Linoleums

To order a color other than those on our list (see pages vi-vii), refer to Nevamar or Formica standard grade, matte texture laminate offerings and Forbo Furniture Linoleums (excluding manufacturers' non-standard matte offering).

Nucraft can support other laminate and linoleum options beyond what can be found as standard options on pages vi-viii. For pricing, please send a request to quotes@nucraft.com.

Care and Maintenance of Laminate and Novawrap

Laminate and Novawrap surfaces may be cleaned with a damp cloth and ordinary soap or non-abrasive household liquid detergent. Dry the surface with a clean cloth or soft paper towel to prevent streaks from appearing.

Care and Maintenance of Metal

Metal surfaces can be wiped with a damp cloth and rubbed dry. A mild non-abrasive household liquid detergent can be used if necessary. Regular maintenance of metal components, including tightening of fasteners and light lubrication of moving parts, will extend the life of your furniture.

Satin Etched Glass

Glass color may vary slightly on multi-piece conference table tops over 180" x 60" when satin etched glass is specified due to the iron content and etching process of the glass.

Care and Maintenance of Glass

Clear or frosted glass may be cleaned with commercial glass cleaner. Be sure to use a lint-free cloth if cleaning the frosted side of the glass.

Stone and Solid Surface Material

Despite its reputation for durability, natural stone can easily be broken during handling and/or installation if proper techniques are not followed. In addition, Nucraft is not responsible for the installation of natural stone or solid surface materials on its products. Therefore, installers specifically trained in the installation of these materials must be utilized to ensure a quality installation. Nucraft shall not be liable for any damages incurred during the handling and/or installation of natural stone or solid surface materials on its products.

Care and Maintenance of Granite

Granite surfaces may be cleaned with a damp cloth and ordinary soap or non-abrasive household liquid detergent. Dry the surface with a clean cloth or soft paper towel to prevent streaks from appearing.

Care and Maintenance of Leather

Genuine leather requires very little care. Nucraft recommends that leather be dusted regularly. If a more thorough cleaning is needed, use lukewarm water and a mild, non-abrasive soap. Generate some lather and lightly rub the surface with cheesecloth. Rinse off any soap film with clean water and towel dry. The leather may dry dull. To restore the leather to a normal gloss, rub it with a clean towel. Never use furniture polish, oil, varnish or ammonia. Saddle soap may be used to prevent the leather from becoming brittle or cracked and to maintain the original supple finish.

Touch Up Finish Kits

Model #	Description	Price
KIT-M	Metal Kit	85
KIT-P	Paint Kit	85
KIT-S	Stain Kit	85

REQUIRED INFORMATION:

(ORDER CANNOT BE ENTERED WITHOUT THIS INFORMATION)

- Kit model number
- Quantity of kits
- Specify finish (See pages vi-vii)

General Information:

- Touch-up kits must be ordered on a purchase order separate from Nucraft product due to Hazmat shipping

Retrofit & Replacements

If needing a partial placement or retrofit solution, please reach out to our quote team. Grain/color matched in a set.



VENEER

STANDARD

Default veneer sheen will vary per finish and were determined by a team of experts who reviewed the colorways to determine if gloss or matte best highlighted the natural characteristics of the species of wood and the color of the stain. Default finish is bolded. If no direction is provided, default sheen will be selected.

	Matte	Gloss
Rift Cut Oak		
Carbon	M03	G03

Flat Cut Oak

Artisan	M68	G68
Coco	M67	G67
Dove	M66	G66
Dune	M05	G05
Midnight	M69	G69
Portobello	M7413	G7413
Winter	M70	G70

Flaky Oak

Sahara	M61	G61
--------	------------	-----

Cherry

Auburn	M93	G93
Cognac	M21	G21

Walnut

Marron	M35	G35
Mocha	M33	G33
Onyx	M82	G82
Otter	M31	G31
Zinc	M30	G30

Maple

Natural Maple	M60	G60
---------------	-----	------------

Linea

Euro Birch Linea	M09	G09
Oak Linea	M08	G08
Silver Birch Linea	M10	G10
Walnut Linea	M27	G27

Paldo

Canyon	M77	G77
Paldo	M76	G76
Thicket	M75	G75

GLASS

	Satin	Gloss
Satin or Gloss Glass		
Black	BS	-
Clove	VS	VG
Meringue	MS	MG
Moonlight	MLS	MLG
Storm	STS	STG
Quill	QS	QG
White	WS	WG

Note: Due to color variation inherent in the natural acid etching process, Satin Etched Glass is not available on tables longer than 180" or wider than 60".

METAL

Powder Coat

Aged Bronze		A8010
Black		A44
Burnished		A8009
Cloud		A8004
Foil		A8006
Galaxy		A8007
Moonlight		A87
Satin Bronze		A8011
Shadow		A8005
Storm		A8012

Metal

Clear Anodized		CA
Polished Chrome	(upcharge applies)	PC

PAINT

Aged Bronze	S8010
Black	S44
Burnished	S88
Cloud	S8004
Foil	S8006
Galaxy	S8007
Moonlight	S87
Satin Bronze	S8011
Shadow	S8005
Storm	S8012

Paint to Match

To request a custom paint color, contact Nucraft Customer Service. A paint sample must be matched and approved prior to order.