

# NUCRAFT

Tesano™ Installation Instructions

ID:

# Before Beginning Installation

- Read through the entire instruction thoroughly
- A minimum of 2 persons is required for this assembly. Tables longer than 96” require 3-4 persons.
- These instructions reflect typical assemblies. They may not match your specific configuration.

# Required Tools

- Drill Driver
- #2-Phillips Bit
- Laser Level
- 1/4" Allen Wrench

Hardware 1



Hardware 2



Hardware 3



Hardware 4



Hardware 5



Hardware 6



# Tesano Conference

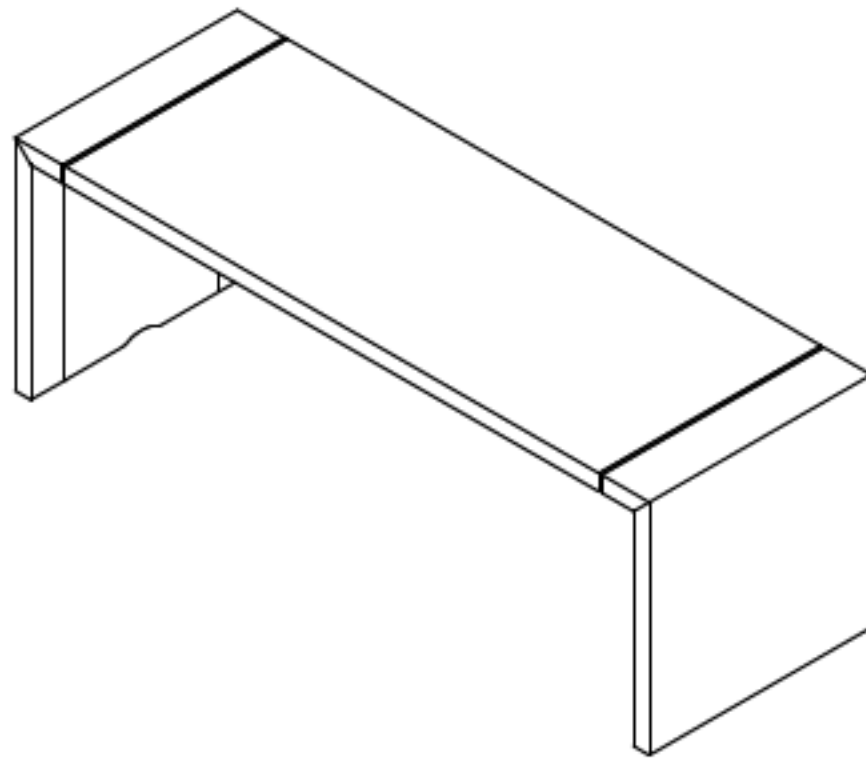

# Tesano Conference Exploded

1. Work Surface
2. Top Beams
3. Mending Plate
4. Base
5. Rail Key
6. Wire Management
7. Power Rail

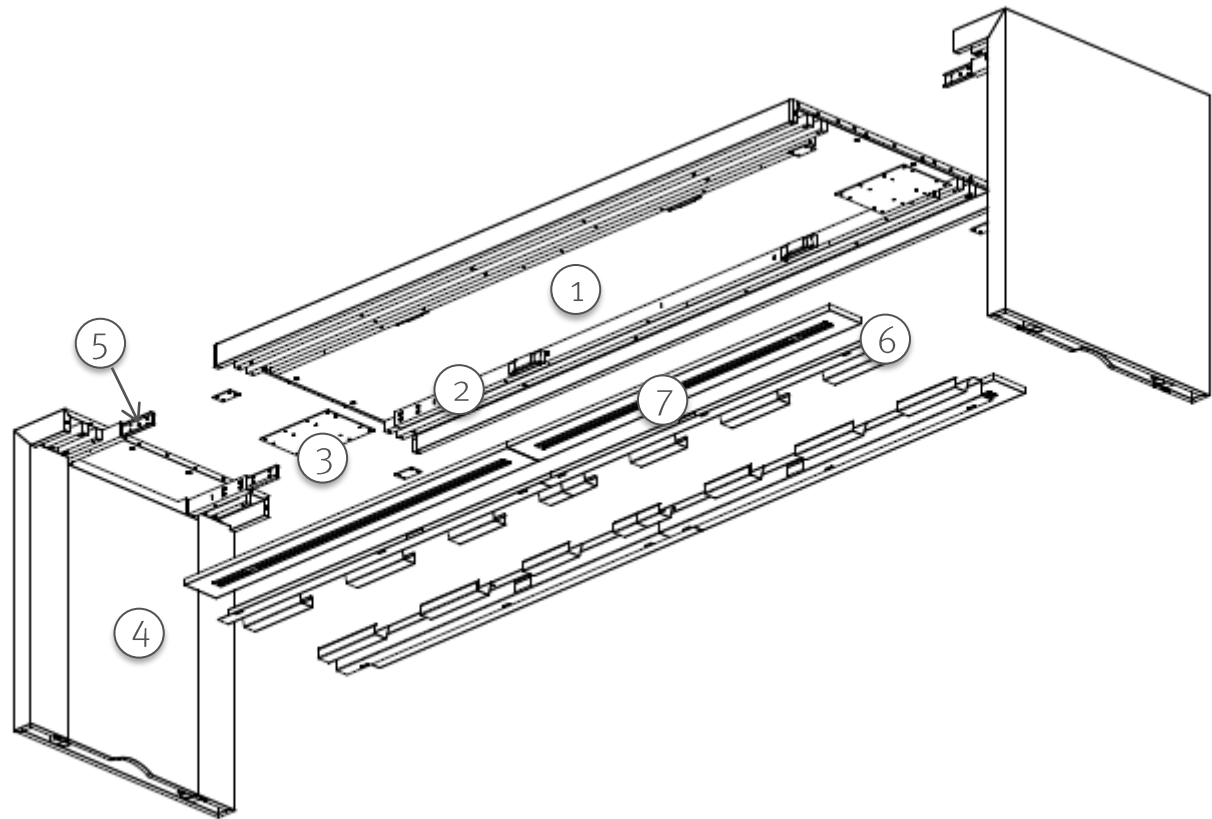

# Step 1: Connecting Rails to Bases

- Run glides out of bases before beginning assembly.
- Loosen bolts (hardware #6) in the keys attached to the beam.
- Insert the beams with rail keys attached, into each of the bases with the “THIS SIDE UP” label facing up and pilot holes facing ground.
- Use labels to attach correct beams to correct bases.

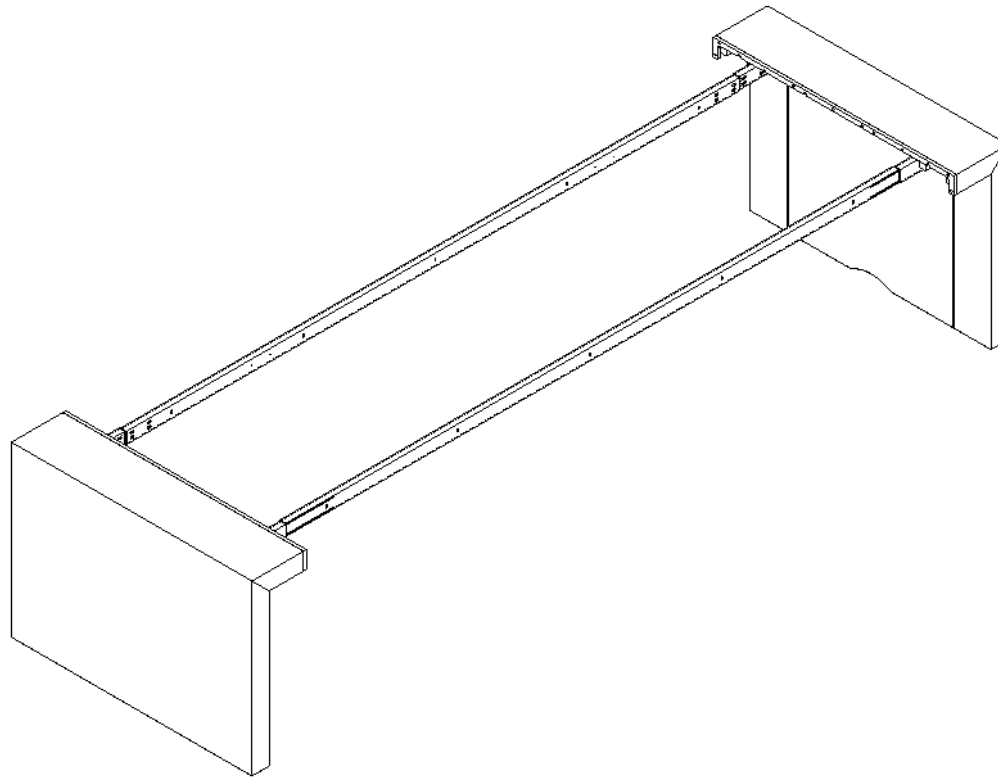

## Step 2: Installing Top

- Insert pins (hardware #4) into the holes along the top edge of base end.
- Place top onto beams, sliding one end into the pins of one base.
- Repeat with the base on the opposite end.
- Tighten the cams to bring the two surfaces flush.
- Make sure the ends match labels.

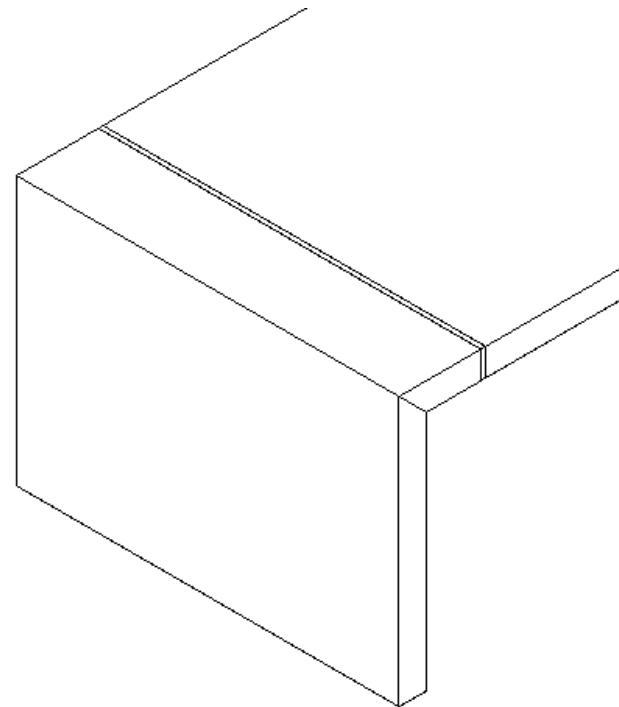
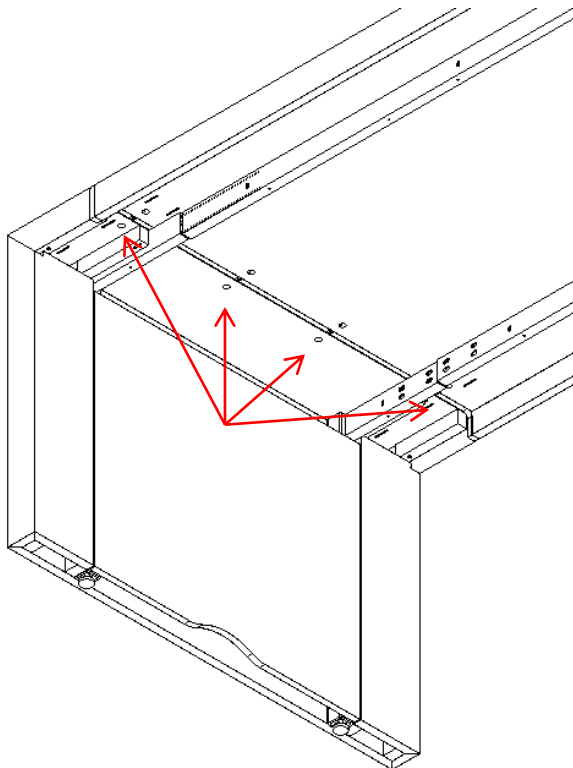

## Step 3: Securing Top with Mending Plates

NOTE: Ensure to center sides of top to the bases prior to attaching mending plates. Square the base up to the top before securing the mending plates.

- Attach mending plate along the center of the metal spacer. Pilot holes should be present.
- Attach smaller mending plates in between the edge of the table and the top wood rails.

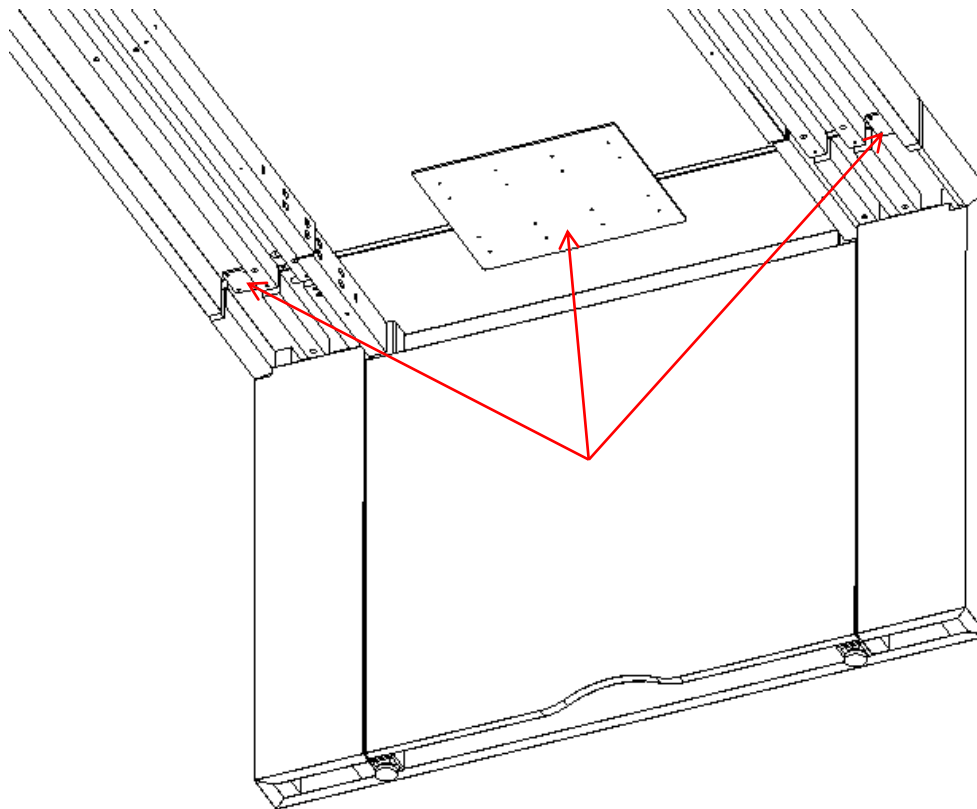



## Step 4: Securing Top Rails

- With the mending plates secured in place, secure the top beams to the wood rails using hardware #5 long silver screws. The pilot holes in the beam should be facing the ground.
- Using cap screws (hardware #6) shown below, insert into side of rail keys.

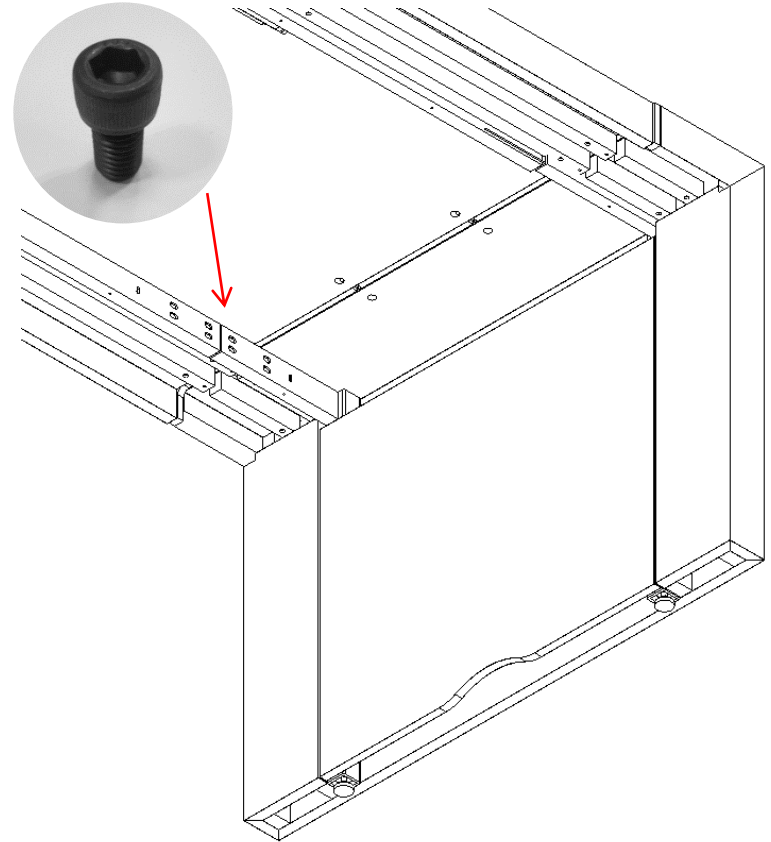

## Step 4: Securing Top Rails

- Center the top beam between the base and the tighten cap screws ensuring bottom of beams are flush with on another.
- Secure the top beams to the wood rails using hardware #5 long silver screws. The screws will go through the slotted openings along the face of the beams.

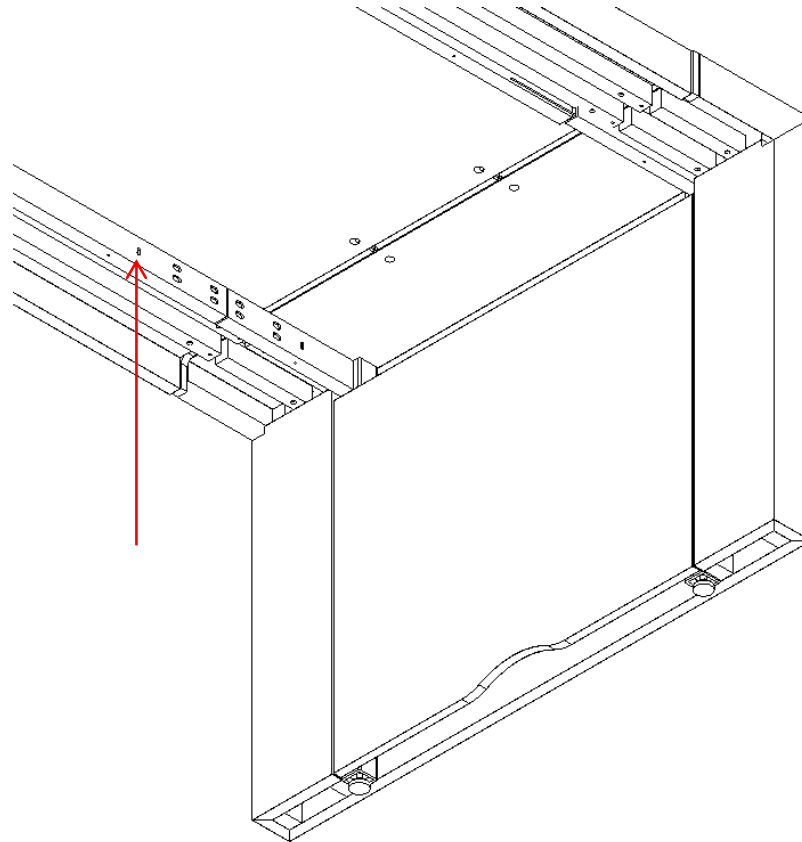

## Step 5: Fastening Aprons

- Locate notch, place in apron toward end of table.
- Place the aprons between the inside of the side rail and the black beam, and fasten them using supplied silver screws (hardware #2). Screws will go THROUGH the aluminum extrusion.

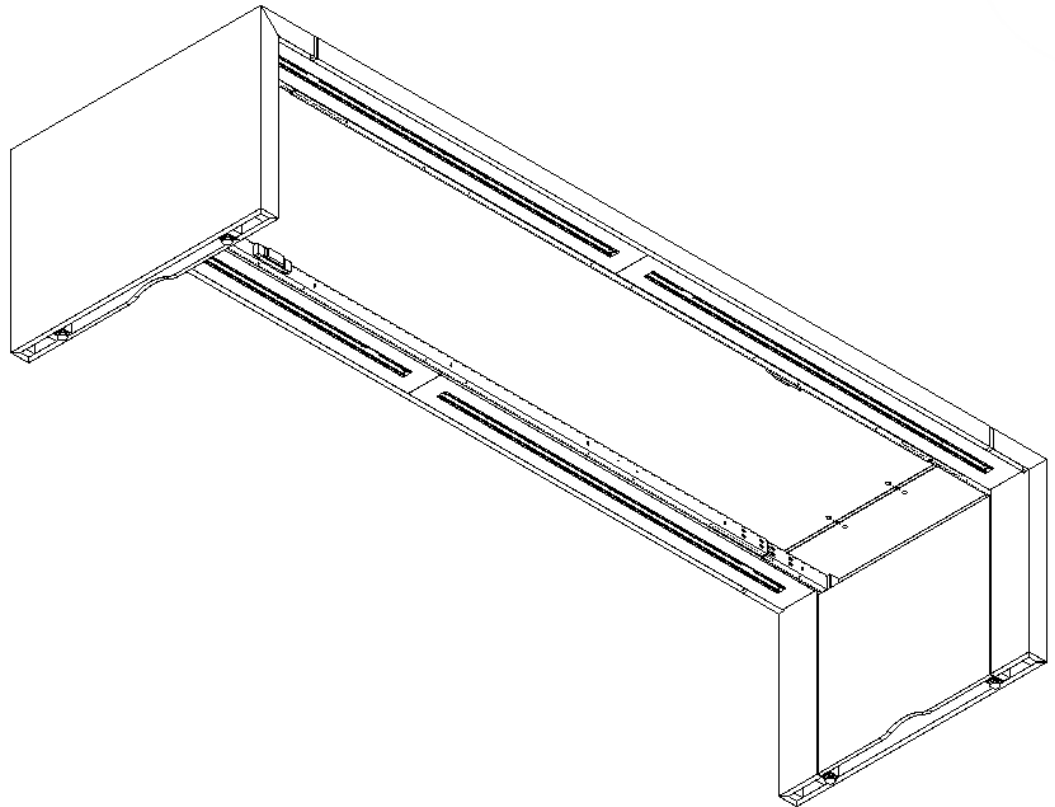
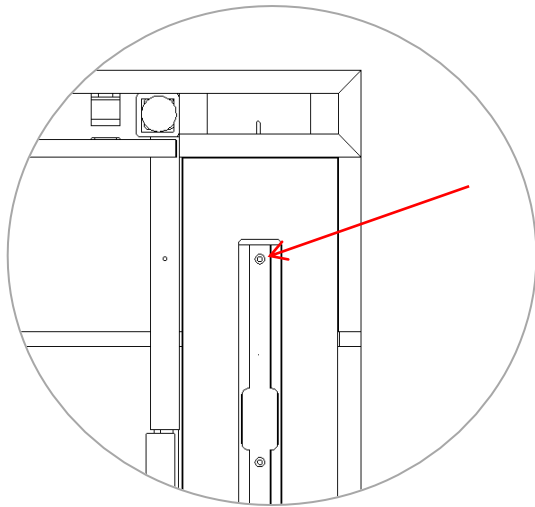

## Step 6: Installing Wire Management

- Attach jumpers to receptacles
- Run the jumpers around the table, in a U-shape design.
- At one end of the table, the plug in-feed or hardware should run through the leg.

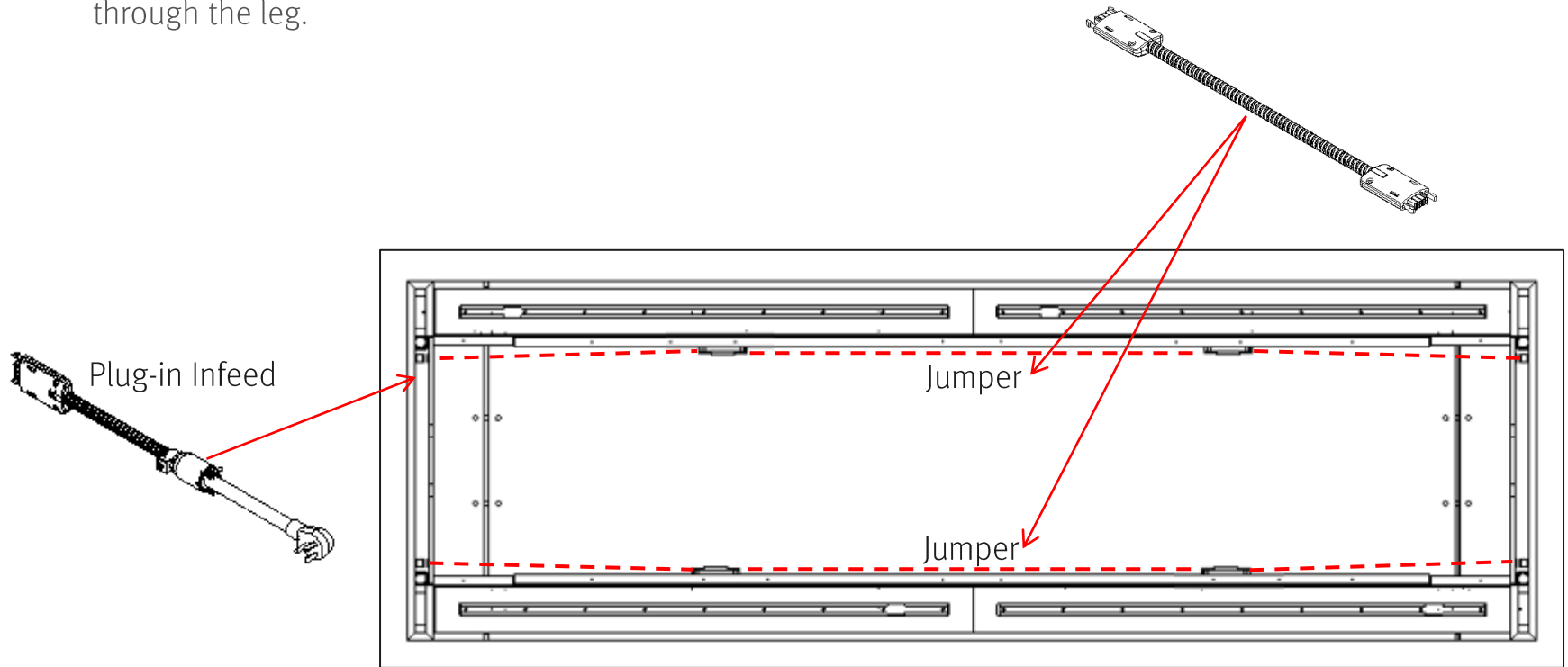

## Step 7: Installing Wire Management Covers

- Locate the wire management channels.
- Ensuring that the power duplex lines up with the cutout, fasten the wire management channel using silver screws (hardware #1) and black screws (hardware #3).
- The label will be facing the top.
- The silver screws (hardware #1) must be used on the raised surface, while the black screws (hardware #3) should be used on the lower surface.

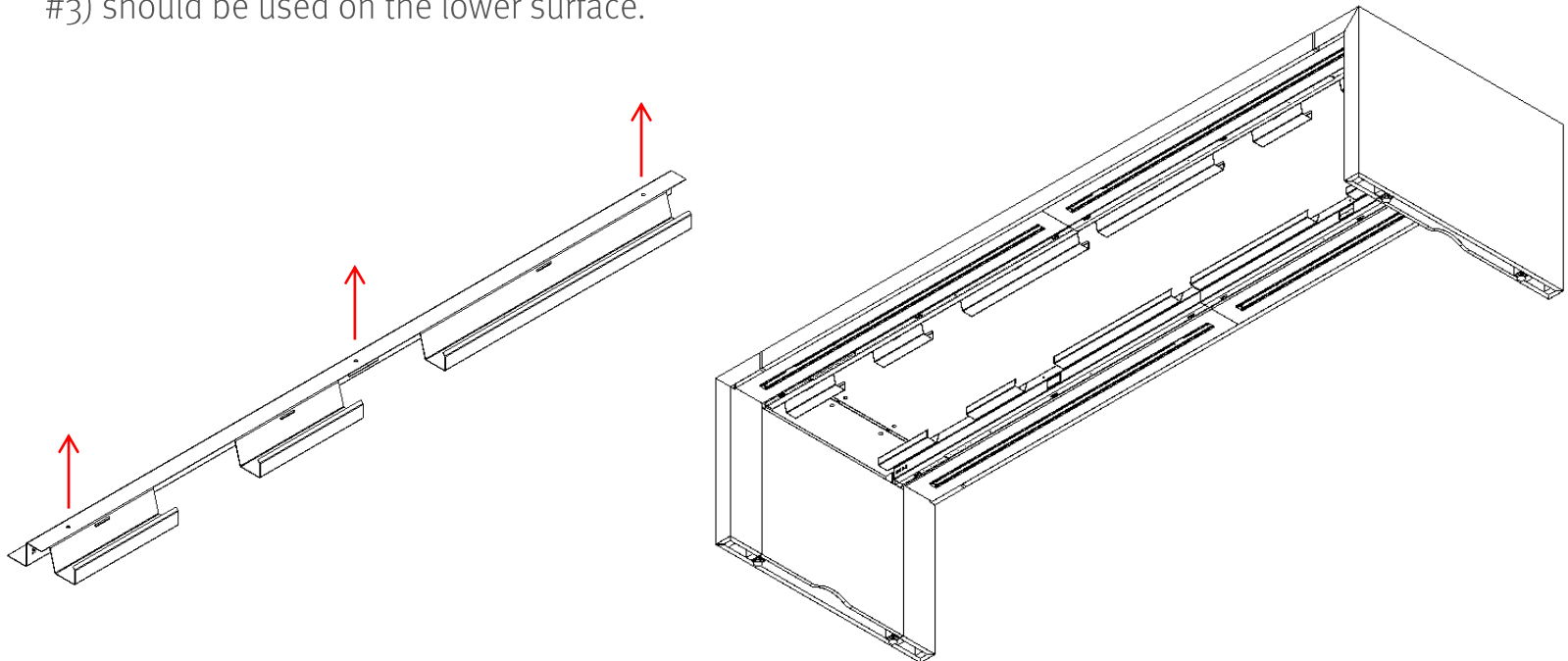

## Step 7: Installing Power Rail Units

- The power rail unit will come with the two black brackets which should be inserted first into the rail.
- The silver bolts should be inserted into the bracket before inserting into rail.
- Place power unit over screws.
- Tighten nuts to secure unit to the rail.

